

# Edixeon<sup>®</sup> K series



Edixeon<sup>®</sup> emitters are built with packages designed specifically for High Power LED. K series, the latest addition to Edixeon<sup>®</sup> family, utilize the advanced special manufacturing process by Edison Opto and the sophisticated EZ Bright 700-1000 chip from Cree Inc.

KLC8 series can be driven at a current rating from 350mA to 1000mA (White) as you desire. With its versatility and exceptional luminous flux output, KLC8 Series is simply the ideal choice for your various illumination needs.

KLD8 series can be driven at a current rating from 350mA to 700mA (White) as you desire with high quality. With its versatility and exceptional luminous flux output, KLD8 series is simply the ideal choice for your various illumination needs.

KLC9 series can be driven at a current rating 350mA (White). With its versatility and exceptional luminous flux output, KLC9 series is simply the ideal choice for your various illumination needs ecumenically.

## Features

- More energy efficient than incandescent and most halogen lamps
- Low voltage operation
- Instant on
- Long life

## Typical Applications

- Reading lights
- Portable flashlight
- Up-lights and Down-lights
- LCD Backlights
- General lighting
- Contour lights
- Ceiling lights
- Garden lighting
- Decoration lights
- Architectural lighting
- Beacon light

---

## Table of Contents

Product Nomenclature .....	2
Environmental Compliance .....	3
LED Package Dimensions and Polarity for KLCx series .....	4
LED Package Dimensions and Polarity for KLD8 series .....	5
LED Package with Star Dimensions and Polarity .....	6
Absolute Maximum Ratings .....	7
Luminous Flux Characteristics .....	8
Forward Voltage Characteristics .....	10
Emission Angle Characteristics .....	10
JEDEC Information .....	11
Reliability Items and Failure Measures .....	12
Color Spectrum and Radiation Pattern .....	13
Color Temperature or Wavelength Characteristics .....	16
CRI Characteristics .....	16
Product Soldering Instructions .....	24
Product Thermal Application Information .....	28
Product Electrical Application Information .....	33
Product Packaging Information .....	34
Star Product Packaging Information .....	36

## Product Nomenclature

The following table describes the available color, power, and lens type. For more flux and forward voltage information, please consult the Bin Group document.

< Table 1 Edixeon® K series nomenclature >

**E D E W - K L C 8 - B 1 - A B 16**

X1		X2		X3		X4		X5		X6		
LED Item		Module		Emitting Color		Power		Lens Item		Housing Item		
Code	Type	Code	Type	Code	Type	Code	Type	Code	Type	Code	Type	
ED	Edixeon®	E	Emitter	W	Cool White	○	K	Cree Chip	L	Lambertian	C	Black-2
		S	Star	H	Neutral White	●					D	Black-3
				X	Warm White	●						

X7		X8		X9		X10		X11		X12	
Material		Phosphor Item		Testing Current		Shape Item		Al PCB Color		Thickness	
				Code	Type	Code	Type	Code	Type	Code	Type
				1	350mA	A	Star	W	White	10	1.0mm
				3	700mA	B	Square(25*25mm)	G	Green	16	1.6mm
				5	1000mA	C	Square(30*30mm)	B	Black	20	2.0mm

### Environmental Compliance

Edixeon® K series are compliant to the Restriction of Hazardous Substances Directive or RoHS. The restricted materials including lead, mercury cadmium hexavalent chromium, polybrominated biphenyls (PBB) and polybrominated diphenyl ether (PBDE) are not used in Edixeon® K series to provide an environmentally friendly product to the customers.

## LED Package Dimensions and Polarity for KLCx series

### Lambertian

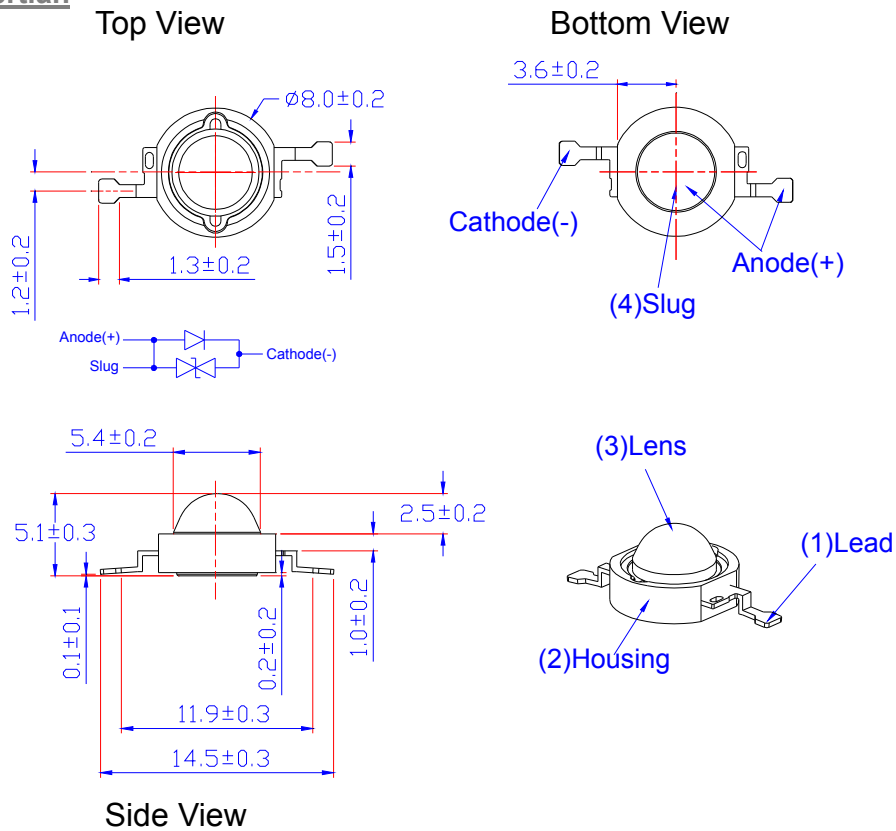

< Figure 1 Edixeon<sup>®</sup> KLCx series dimensions >

#### Notes:

1. All dimensions are measured in mm.
2. The slug has polarity as anode.
3. It is strongly recommended to apply on electrically isolated heat conducting film between the slug and contact surfaces.

## LED Package Dimensions and Polarity for KLD8 series

### Lambertian

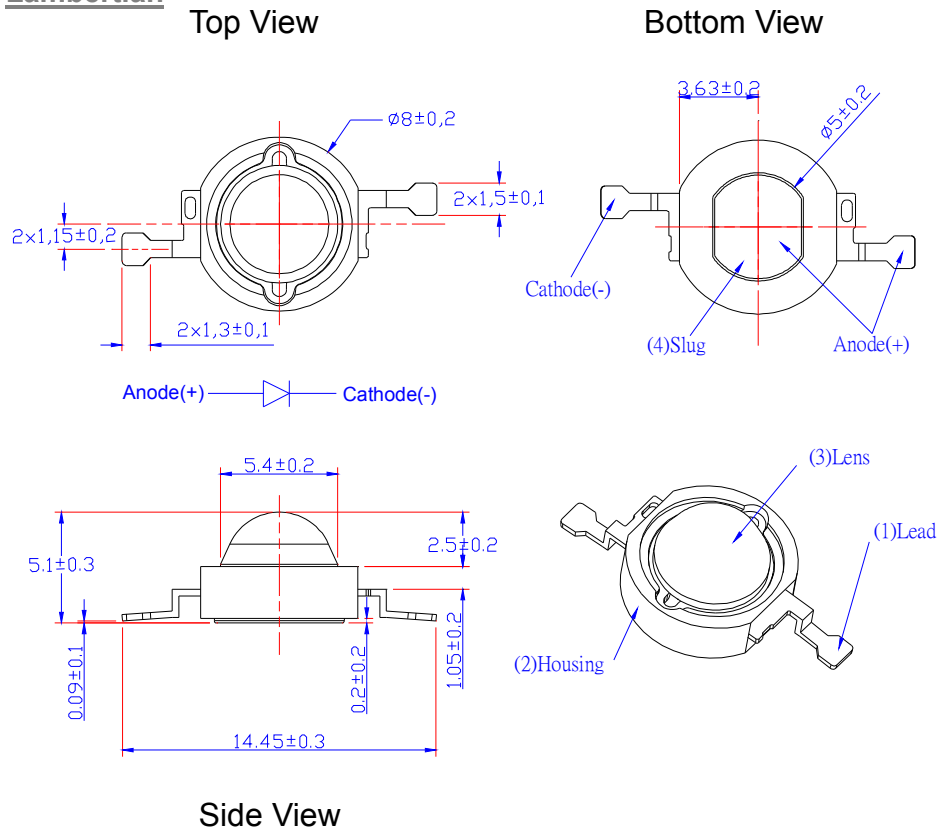

< Figure 2 Edixeon<sup>®</sup> KLD8 series dimensions >

### Notes:

4. All dimensions are measured in mm.
5. The slug has polarity as anode.
6. It is strongly recommended to apply on electrically isolated heat conducting film between the slug and contact surfaces.

## LED Package with Star Dimensions and Polarity

### EDSx-KLxx-xx-Ax16

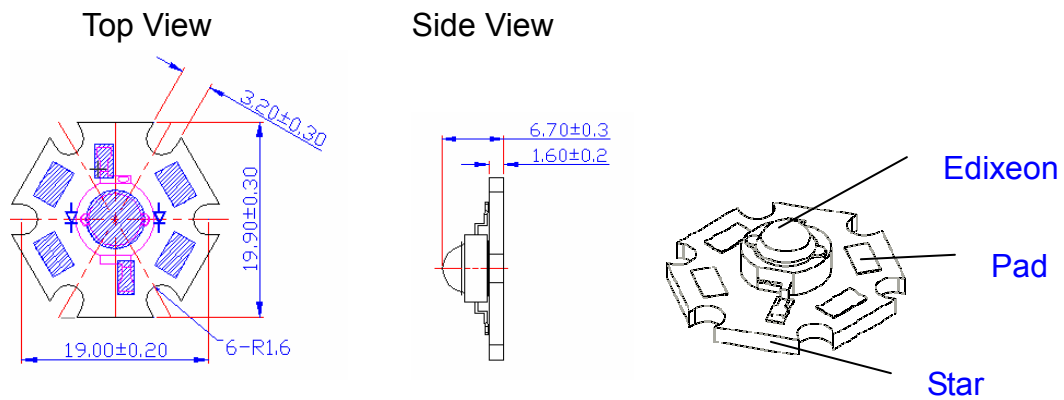

### EDSx-KLxx-xx-Bx16

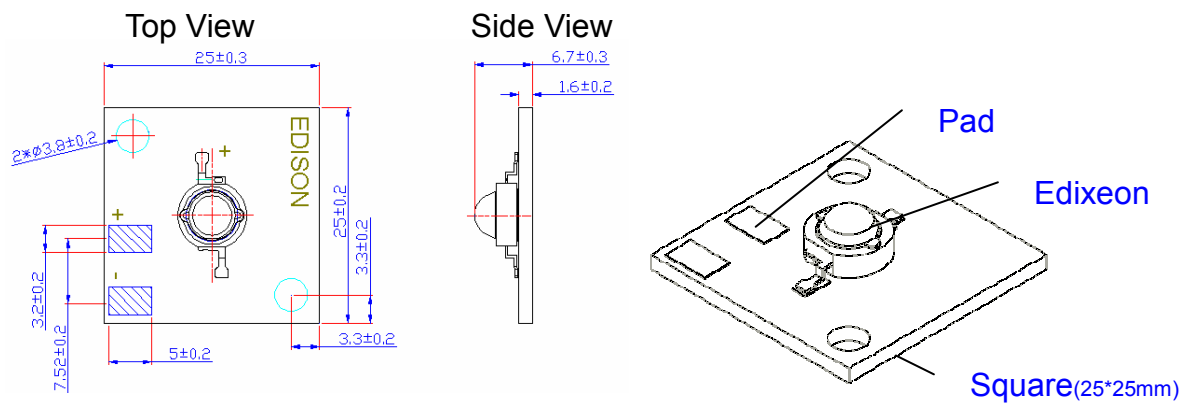

### EDSx-KLxx-xx-Cx16

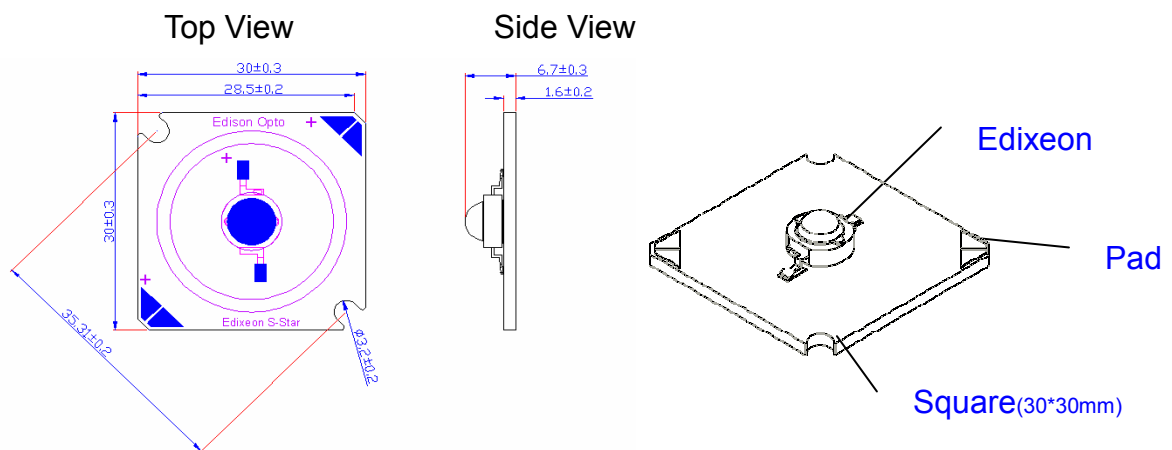

<Figure 3 Edixeon® star dimensions>

#### Notes:

- 1.All Dimensions are in mm.

## Absolute Maximum Ratings

The following tables describe the characteristics of Edixeon® K series under various current.

< Table 2 Edixeon® K series absolute maximum ratings >

Parameter	Rating	Unit	Symbol
DC Forward Current (KLC8)	1,000	mA	I <sub>F</sub>
DC Forward Current (KLD8)	700	mA	I <sub>F</sub>
DC Forward Current (KLC9)	350	mA	I <sub>F</sub>
Peak pulse current (tp ≤ 100μs, Duty cycle=0.25) (KLC8)	1,500	mA	
Peak pulse current (tp ≤ 100μs, Duty cycle=0.25) (KLD8)	1,000	mA	
Peak pulse current (tp ≤ 100μs, Duty cycle=0.25) (KLC9)	500	mA	
Reverse Voltage	5	V	V <sub>R</sub>
Supply Voltage	5	V	V <sub>S</sub>
LED junction Temperature	125	°C	T <sub>J</sub>
Operating Temperature	-30 ~ +110	°C	
Storage Temperature	-40 ~ +120	°C	
Storage Relative Humidity	60	%	
ESD Sensitivity	4,000	V	V <sub>B</sub>
Manual Soldering Time at 260°C (Max.)	5	Sec.	

### Notes:

1. Proper current derating must be observed to maintain junction temperature below the maximum at all time.
2. LEDs are not designed to be driven in reverse bias.
3. tp: Pulse width time

The following table describes thermal resistance of Edixeon® K series.

< Table 3 Thermal Resistance Junction to Solder Pad Characteristics at T<sub>J</sub>=25°C for Edixeon® K series >

Part Name	Typ.	R <sub>θJ-B</sub>	Unit
EDEX-KLC8-xx	8		°C/W
EDEX-KLD8-xx	13		°C/W
EDEX-KLC9-xx	15		°C/W

## Luminous Flux Characteristics

The following tables describe flux of Edixeon® K series under various current and different color.

< Table 4 Luminous flux characteristics at  $I_f=350\text{mA}$  and  $T_J=25^\circ\text{C}$ : >

Lens Item	Part Name	Color	Flux/ Radiometric Power <sup>[1]</sup>			Unit
			Min.	Typ.	Max.	
Lambertian	EDEW-KLC8-B1	Cool White	51.2	85.0	--	lm
	EDEW-KLD8-B1	Cool White	51.2	80.0	--	lm
	EDEW-KLC9-B1	Cool White	39.4	65.0	--	lm
	EDEH-KLC8-C1	Neutral White	39.4	65.0	--	lm
	EDEH-KLC8-E1	Neutral White	39.4	65.0	--	lm
	EDEH-KLC9-E1	Neutral White	30.3	45.0	--	lm
	EDEX-KLC8-C1	Warm White	30.3	50.0	--	lm
	EDEX-KLC8-E1	Warm White	30.3	50.0	--	lm
	EDEX-KLC9-E1	Warm White	23.3	40.0	--	lm
	EDEB-KLC8-01	Blue	13.8	25.0	--	lm
	EDED-KLC8-01	Dental Blue <sup>[1]</sup>	170.9	260.2	--	mW
	EDEC-KLC8-01	Royal Blue <sup>[1]</sup>	170.9	280.0	--	mW
	EDEW-KLC8-D1	Cool White	39.4	50.0	--	lm
	EDEH-KLC8-D1	Neutral White	23.3	40.0	--	lm
	EDEX-KLC8-D1	Warm White	23.3	35.0	--	lm

< Table 5 Luminous flux characteristics at  $I_F=700\text{mA}$  and  $T_J=25^\circ\text{C}$  : >

Lens Item	Part Name	Color	Flux/ Radiometric Power <sup>[1]</sup>			Unit
			Min.	Typ.	Max.	
Lambertian	EDEW-KLC8-B3	Cool White	112.5	140.0	--	lm
	EDEW-KLD8-B3	Cool White	86.5	125.0	--	lm
	EDEH-KLC8-C3	Neutral White	86.5	100.0	--	lm
	EDEH-KLC8-E3	Neutral White	86.5	100.0	--	lm
	EDEX-KLC8-C3	Warm White	66.5	95.0	--	lm
	EDEX-KLC8-E3	Warm White	66.5	95.0	--	lm
	EDEB-KLC8-03	Blue	23.3	36.0	--	lm
	EDED-KLC8-03	Dental Blue <sup>[1]</sup>	256.3	420.0	--	mW
	EDEC-KLC8-03	Royal Blue <sup>[1]</sup>	256.3	465.0	--	mW
	EDEW-KLC8-D3	Cool White	51.2	75.0	--	lm
	EDEH-KLC8-D3	Neutral White	51.2	65.0	--	lm
	EDEX-KLC8-D3	Warm White	39.4	60.0	--	lm

< Table 6 Luminous flux characteristics at  $I_F=1,000\text{mA}$  and  $T_J=25^\circ\text{C}$  : >

Lens Item	Part Name	Color	Flux/ Radiometric Power <sup>[1]</sup>			Unit
			Min.	Typ.	Max.	
Lambertian	EDEW-KLC8-B5	Cool White	146.2	180.0	--	lm
	EDEH-KLC8-C5	Neutral White	86.5	125.0	--	lm
	EDEH-KLC8-E5	Neutral White	86.5	125.0	--	lm
	EDEX-KLC8-C5	Warm White	86.5	115.0	--	lm
	EDEX-KLC8-E5	Warm White	86.5	115.0	--	lm
	EDEB-KLC8-05	Blue	30.3	50.0	--	lm
	EDED-KLC8-05	Dental Blue <sup>[1]</sup>	384.4	530.0	--	mW
	EDEC-KLC8-05	Royal Blue <sup>[1]</sup>	384.4	580.0	--	mW

**Notes:**

1. Flux is measured with an accuracy of  $\pm 10\%$
2. Blue power light source represented here is IEC60825 class 2 for eye safety.

## Forward Voltage Characteristics

The following table describes forward voltage of Edixeon® K series under various current.

< Table 7 Forward voltage characteristics at  $I_F=350\text{mA}\sim 1,000\text{mA}$  and  $T_J=25^\circ\text{C}$  >

Lens Item	Part Name	Forward Current (mA)	$V_F$			Unit
			Min.	Typ.	Max.	
Lambertian	EDEX-KLC8-x1	350	2.8	--	3.7	V
	EDEX-KLC8-x3	700	3.1	--	4.0	
	EDEX-KLC8-x5	1,000	3.4	--	4.3	
	EDEW-KLD8-B1	350	2.8	--	3.7	
	EDEW-KLD8-B3	700	3.1	--	4.0	
	EDEX-KLC9-x1	350	3.4	--	4.3	

### Note:

1. Forward voltage is measured with an accuracy of  $\pm 0.1\text{V}$

## Emission Angle Characteristics

< Table 8 Emission angle characteristics at  $T_J=25^\circ\text{C}$  >

Lens Item	Part Name	$2\theta_{1/2}(\text{Typ.})$	Unit
		Lambertian	
Lambertian	EDEX-KLC8-xx	120	Deg.
	EDEX-KLC9-xx	120	Deg.
	EDEW-KLD8-xx	120	Deg.

## JEDEC Information

JEDEC has defined a moisture sensitivity classification. So that the users can properly store and handle the devices and to avoid subsequent thermal and mechanical damage during the assembly reflow attachment or repair operation.

The present moisture sensitivity standard contains six levels, the lower the level, the longer the devices floor life. Edixeon<sup>®</sup> K series are certified at level 2a. This means Edixeon<sup>®</sup> K series have a floor life of 4 weeks before K series need to re-baked.

< Table 9 JEDEC characteristics at  $I_F=350mA/700mA/1000mA$  and  $T_J=25^\circ C$  >

Level	Floor Life		Soak Requirements			
	Time	Conditions	Standard Time (hours)	Standard Conditions	Accelerated Environment Time (hours)	Accelerated Environment Conditions
2a	4 weeks	$\leq 30^\circ C / 60\% RH$	$696^1 +5/-0$	$30^\circ C / 60\% RH$	$120 +1/-0$	$60^\circ C / 60\% RH$

Level	Floor Life		Soak Requirements			
			Standard		Accelerated Equivalent	
	Time	Condition	Time(hours)	Condition	Time(hours)	Condition
1	Unlimited	$\leq 30^\circ C / 85\% RH$	$168 +5/-0$	$85^\circ C / 85\% RH$		
2	1 year	$\leq 30^\circ C / 60\% RH$	$168 +5/-0$	$85^\circ C / 60\% RH$		
2a	4 weeks	$\leq 30^\circ C / 60\% RH$	$696^1 +5/-0$	$30^\circ C / 60\% RH$	$120 +1/-0$	$60^\circ C / 60\% RH$
3	168 hours	$\leq 30^\circ C / 60\% RH$	$192^1 +5/-0$	$30^\circ C / 60\% RH$	$40 +5/-0$	$60^\circ C / 60\% RH$
4	72 hours	$\leq 30^\circ C / 60\% RH$	$96^1 +5/-0$	$30^\circ C / 60\% RH$	$20 +5/-0$	$60^\circ C / 60\% RH$
5	48 hours	$\leq 30^\circ C / 60\% RH$	$72^1 +5/-0$	$30^\circ C / 60\% RH$	$15 +5/-0$	$60^\circ C / 60\% RH$
5a	24 hours	$\leq 30^\circ C / 60\% RH$	$48^1 +5/-0$	$30^\circ C / 60\% RH$	$10 +5/-0$	$60^\circ C / 60\% RH$
6	Time on label (TOL)	$\leq 30^\circ C / 60\% RH$	TOL	$30^\circ C / 60\% RH$		

### Note:

- The standard soak time includes a default value of 24 hours for semiconductor manufacturer's exposure time (MET) between bake and bag, and includes the maximum time allowed out of the bag at the distributor's facility.

## Reliability Items and Failure Measures

### Reliability test

The following table describes operating life, mechanical, and environmental tests performed on Edixeon® K series package.

< Table 9 Operating life, mechanical, and environmental characteristics at  $I_F=350\text{mA}\sim 1000\text{mA}$  and  $T_J=25^\circ\text{C}$  >

Stress Test	Stress Conditions	Stress Duration	Failure Criteria
Room Temperature Operating Life	$25^\circ\text{C}$ , $I_F = \text{max DC}$ (Note 1)	1,000 hours	Note 2
High Temperature High Humidity	$85^\circ\text{C}$ / 85%RH	1,000 hours	Note 2
Temperature Cycle	$-40^\circ\text{C}/100^\circ\text{C}$ ,30 min dwell / <5min transfer	500 cycles	Note 2
High Temperature Storage Life	$110^\circ\text{C}$	1,000 hours	Note 2
Low Temperature Storage Life	$-40^\circ\text{C}$	1,000 hours	Note 2
Thermal Shock	$-40 / 125^\circ\text{C}$ , 15 min dwell / < 10 sec transfer	1,000 cycles	No catastrophics
Mechanical Shock	1500 G, 0.5 msec pulse, 5 shocks each of 6 axis		No catastrophics
Solder Heat Resistance (SHR)	$260^\circ\text{C} \pm 5^\circ\text{C}$ , 10 sec		No catastrophics

#### Notes:

- Depending on the maximum derating curve.
- Failure Criteria:
  - Electrical failures
  - $V_F$  shift  $\geq 10\%$
  - Light Output Degradation
  - %  $I_v$  shift  $\geq 30\%$  @1,000hrs or 200cycle
  - Visual failures
  - Broken or damaged package or lead
  - Solderability < 95% wetting
  - Dimension out of tolerance

### ASSIST FORM for high power LED reliability (Ex: Edixeon® @350mA)

< Table 11 Different junction temperature characteristics >

	$T_s=45^\circ\text{C}$	$T_s=65^\circ\text{C}$	$T_s=85^\circ\text{C}$
Voltage	3.3V	3.3V	3.3V
Current	350mA	350mA	350mA
Wattage	1.15W	1.15W	1.15W
Heat	0.92W	0.92W	0.92W
$R_{th}$	$10^\circ\text{C/W}$	$10^\circ\text{C/W}$	$10^\circ\text{C/W}$
$T_J$	$54.2^\circ\text{C}$	$74.2^\circ\text{C}$	$94.2^\circ\text{C}$
$L_{70\%}$	64,000hrs	34,000hrs	19,500hrs

## Color Spectrum and Radiation Pattern

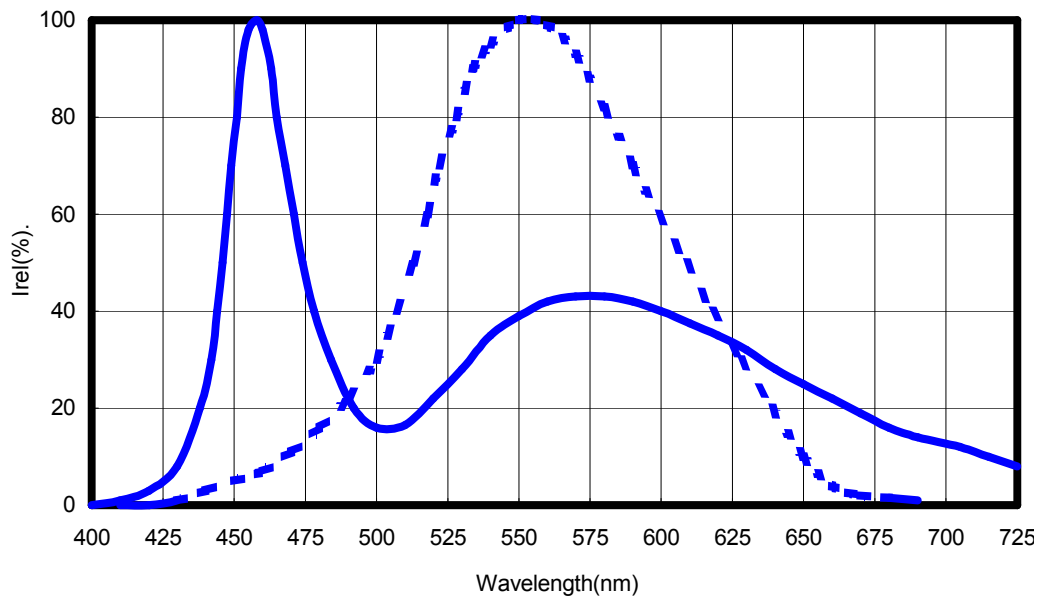

< Figure 4 Color spectrum of typical CCT, standard eyes response to dotted curve line at  $T_J=25^{\circ}\text{C}$  . for KLC8-Bx Edixeon<sup>®</sup> K series cool white >

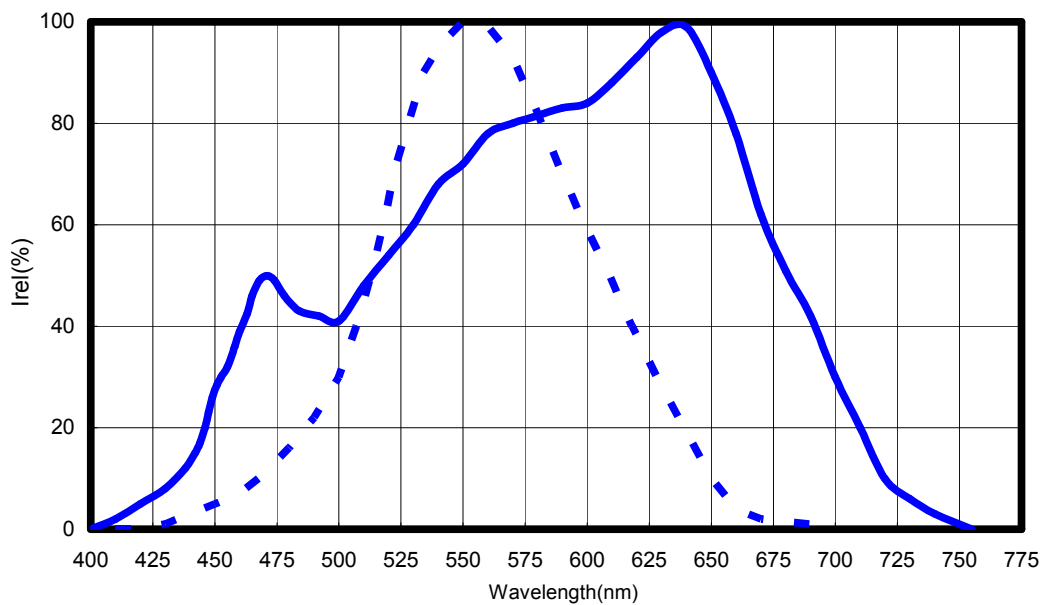

< Figure 5 Color spectrum of typical CCT, standard eyes response to dotted curve line at  $T_J=25^{\circ}\text{C}$  . for KLC8-Cx and KLC8-Ex Edixeon<sup>®</sup> K series neutral white · warm white >

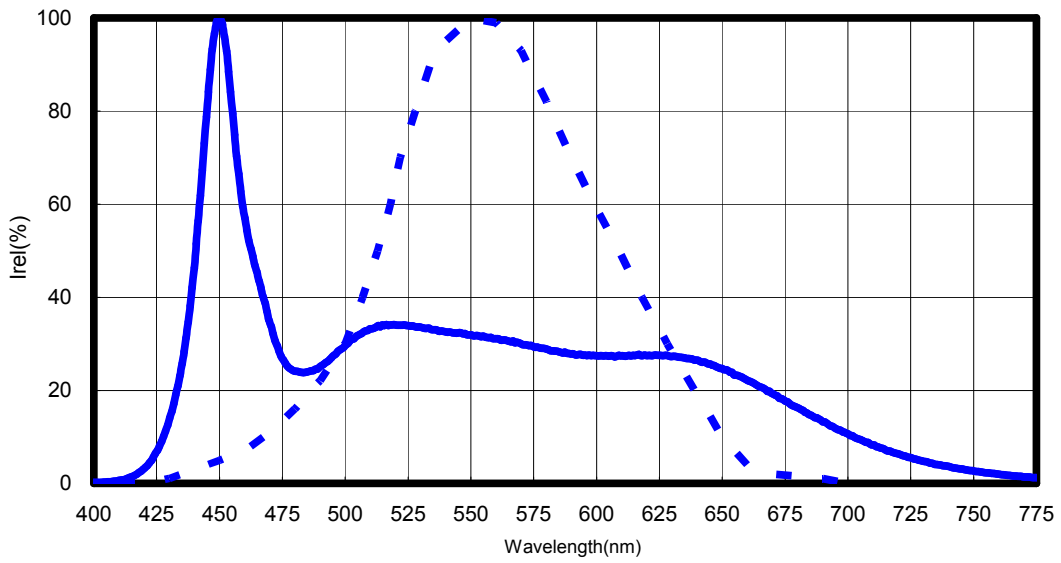

< Figure 6 Color spectrum of typical CCT, standard eyes response to dotted curve line at  $T_j=25^\circ\text{C}$ . for KLC8-Dx Edixeon® K series cool white >

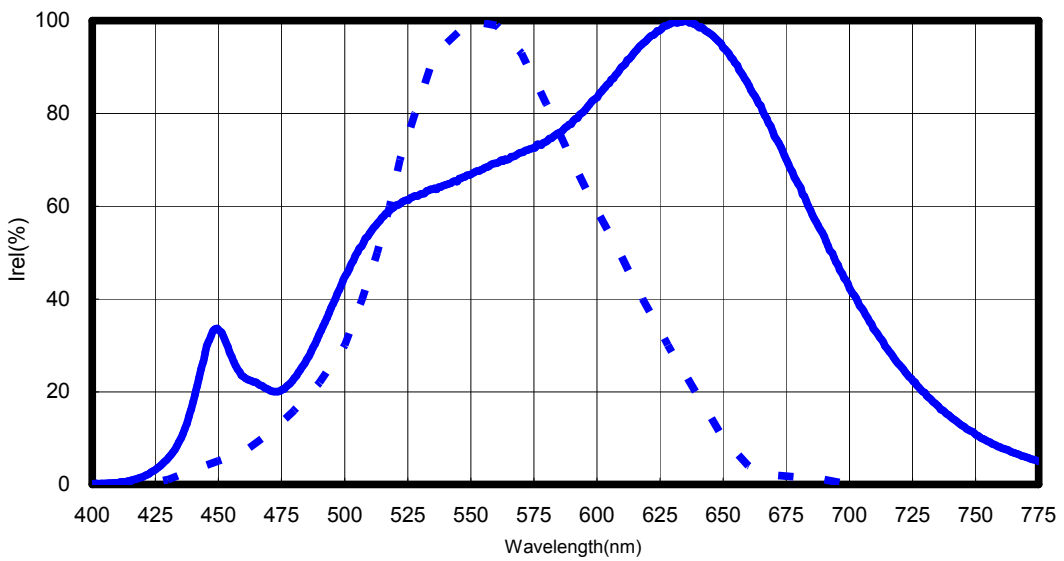

< Figure 7 Color spectrum of typical CCT, standard eyes response to dotted curve line at  $T_j=25^\circ\text{C}$ . for KLC8-Dx Edixeon® K series neutral white ,and warm white >

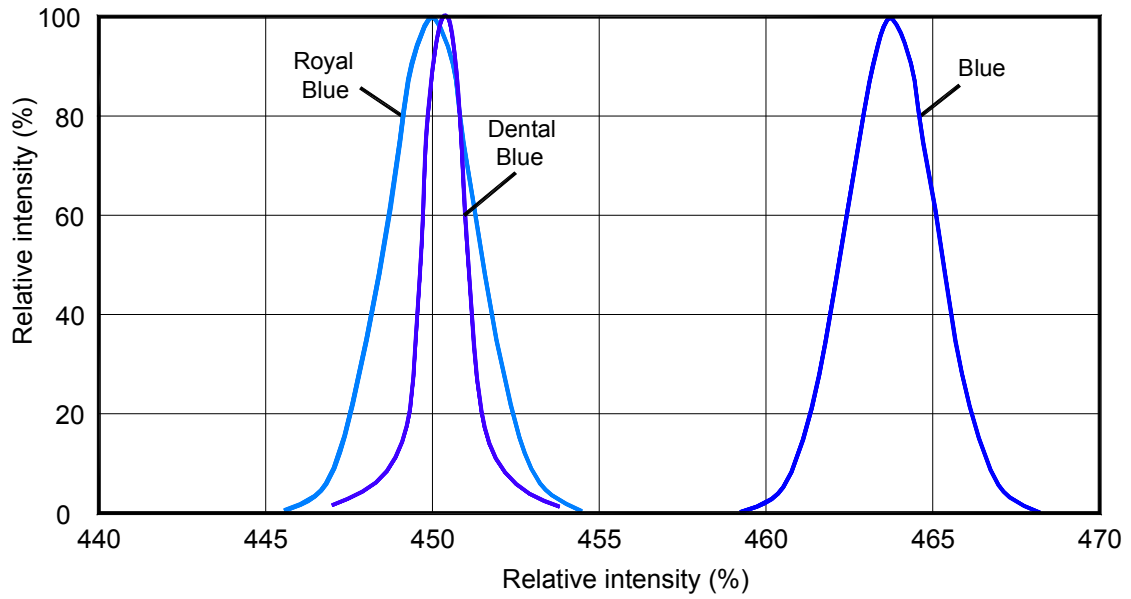

< Figure 8 Blue and royal blue typical wavelength at  $T_J=25^\circ\text{C}$ .>

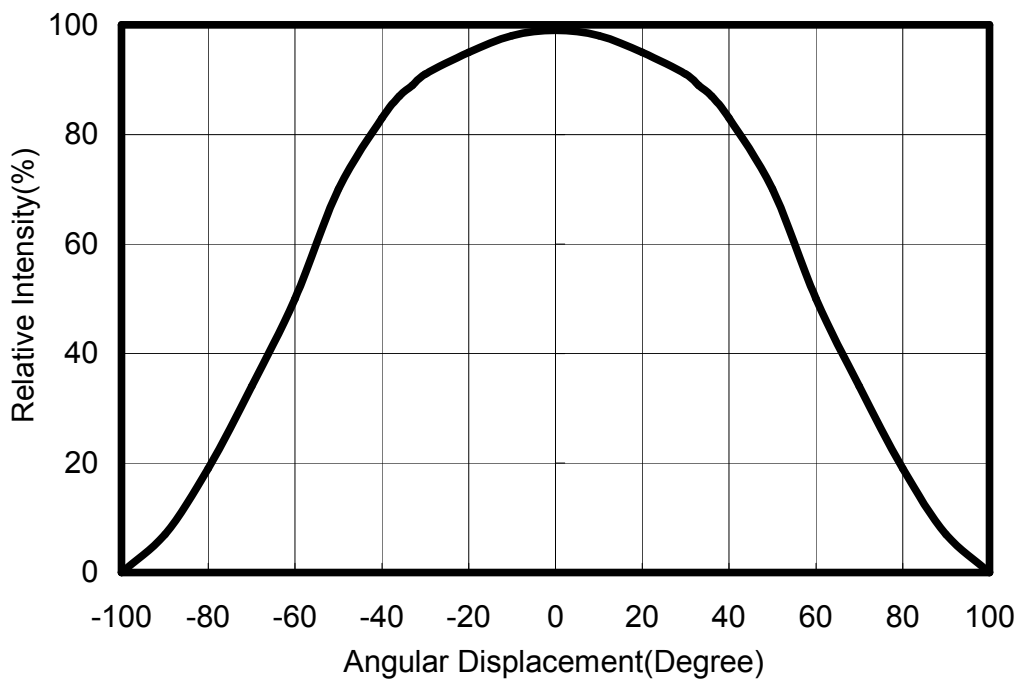

< Figure 9.Lambertain for all colors at  $T_J=25^\circ\text{C}$ .>

## Color Temperature or Wavelength Characteristics

< Table 12 Dominant Wavelength、Peak wavelength<sup>[1]</sup> or Color Temperature Characteristics at  $T_J=25^\circ\text{C}$  >

Lens Item	Part Name	Color	$\lambda_d/\lambda_p^{[1]}/\text{CCT}$			Unit
			Min.	Typ.	Max.	
Lambertian	EDEW-KLC8-Bx	Cool White	5,000	--	10,000	K
	EDEW-KLC8-Dx	Cool White	5,000	--	10,000	K
	EDEH-KLC8-Cx	Neutral White	3,800	--	5,000	K
	EDEH-KLC8-Dx	Neutral White	3,800	--	5,000	K
	EDEH-KLC8-Ex	Neutral White	3,800	--	5,000	K
	EDEX-KLC8-Cx	Warm White	2,670	--	3,800	K
	EDEX-KLC8-Dx	Warm White	2,670	--	3,800	K
	EDEX-KLC8-Ex	Warm White	2,670	--	3,800	K
	EDEB-KLC8-0x	Blue	460	--	475	nm
	EDED-KLC8-0x	Dental Blue <sup>[1]</sup>	450	--	470	nm
	EDEC-KLC8-0x	Royal Blue <sup>[1]</sup>	440	--	460	nm
	EDEW-KLC9-B1	Cool White	5,000	--	10,000	K
	EDEH-KLC9-Ex	Neutral White	3,800	--	5,000	K
	EDEX-KLC9-E1	Warm White	2,670	--	3,800	K
	EDEW-KLD8-B3	Cool White	5,000	--	10,000	K

## CRI Characteristics

< Table 13 CRI characteristics at  $T_J=25^\circ\text{C}$  >

Lens Item	Part Name	Color	CRI Typ.
Lambertian	EDEW-KLxx-Bx	Cool White	70
	EDEW-KLxx-Dx	Cool White	90
	EDEH-KLxx-Cx	Neutral White	80
	EDEH-KLxx-Dx	Neutral White	90
	EDEH-KLxx-Ex	Neutral White	80
	EDEX-KLxx-Cx	Warm White	80
	EDEX-KLxx-Dx	Warm White	90
	EDEX-KLxx-Ex	Warm White	80

### Optical & Electrical Characteristics

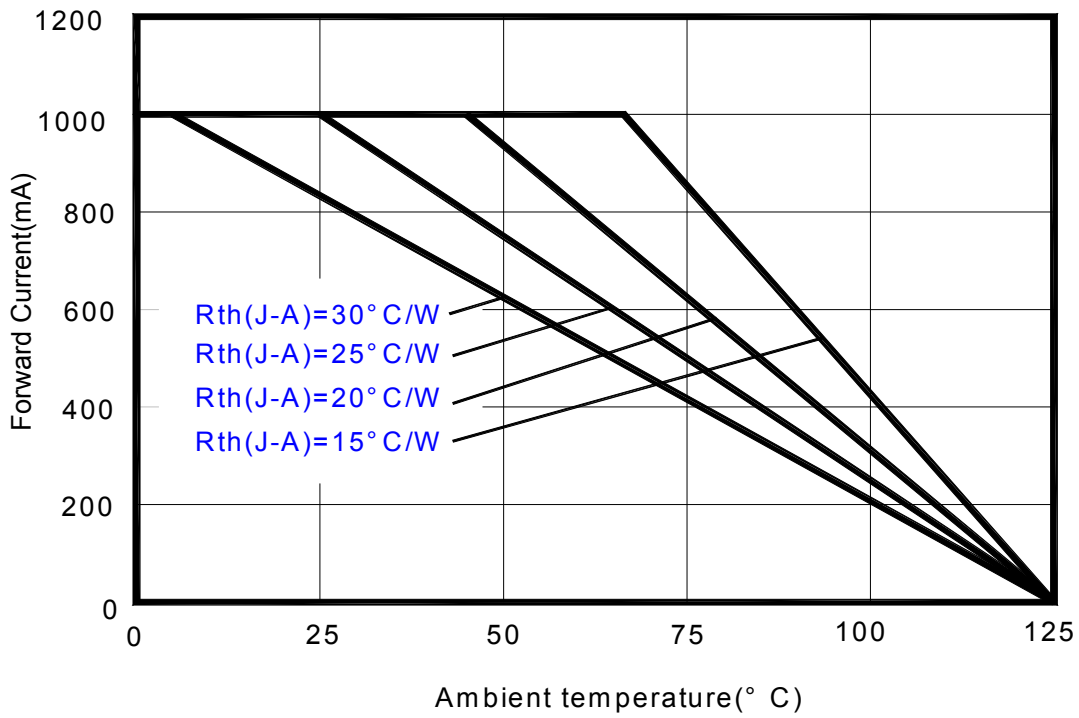

<Figure 10 Forward current & ambient temperature for KLC8 at 1000mA>

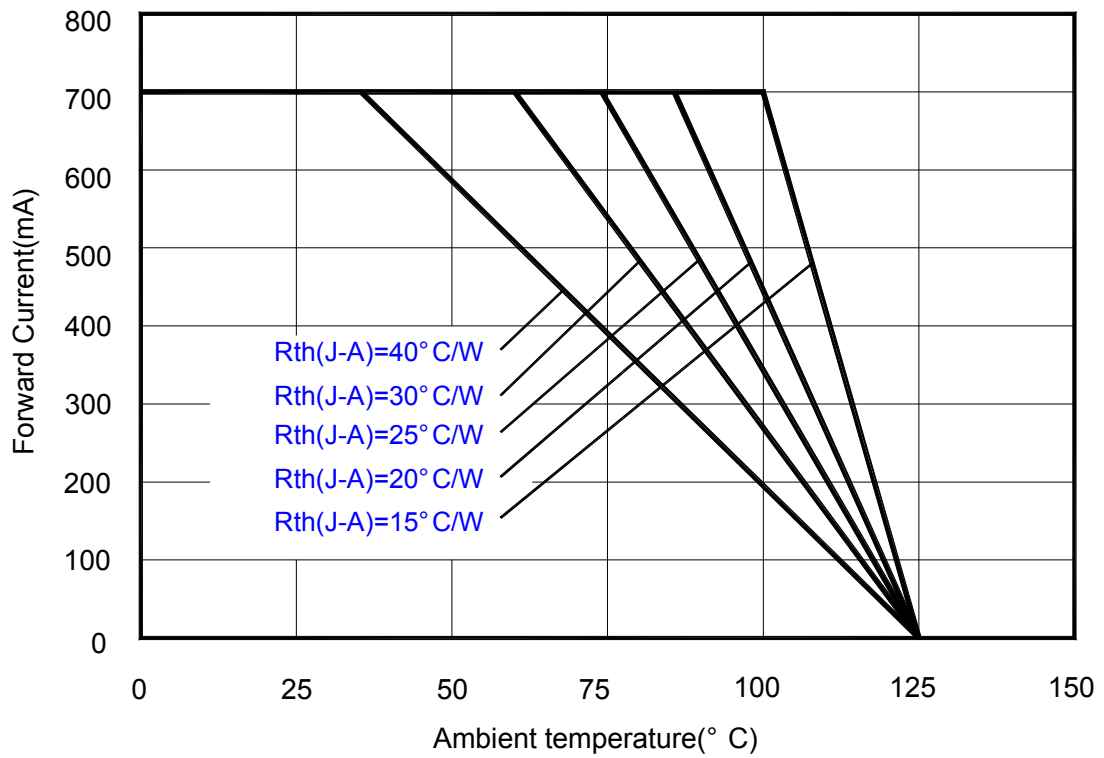

<Figure 11 Forward current & ambient temperature for KLC8 and KLD8 at 700mA>

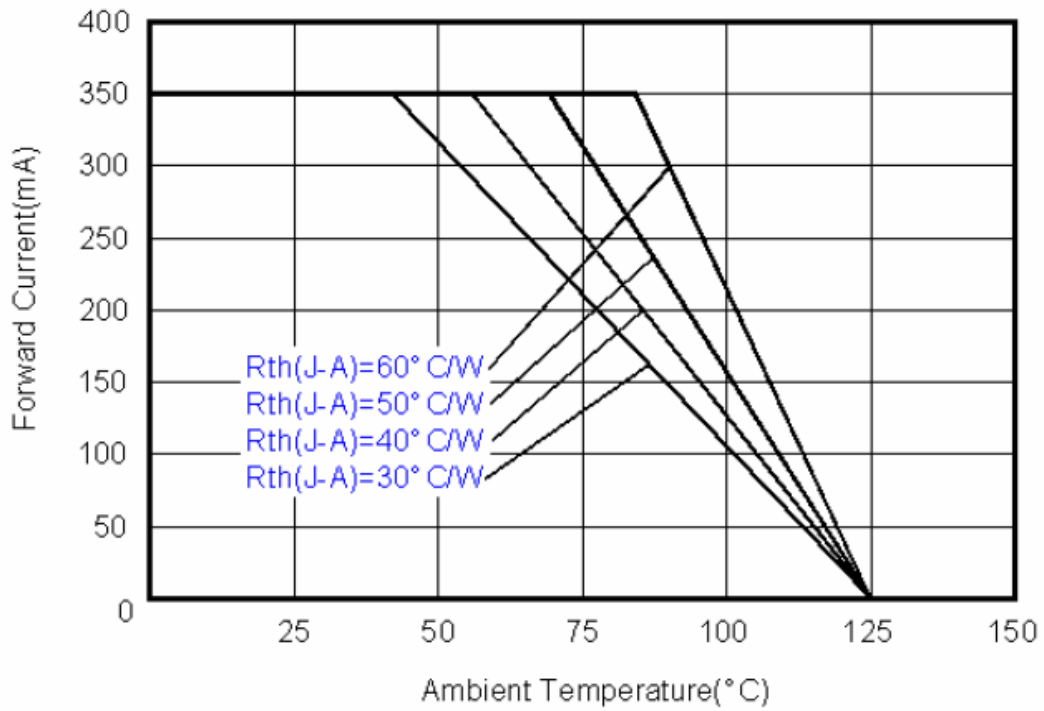

< Figure 12 Forward current & ambient temperature for KLC9 and KLC8 at 350mA >

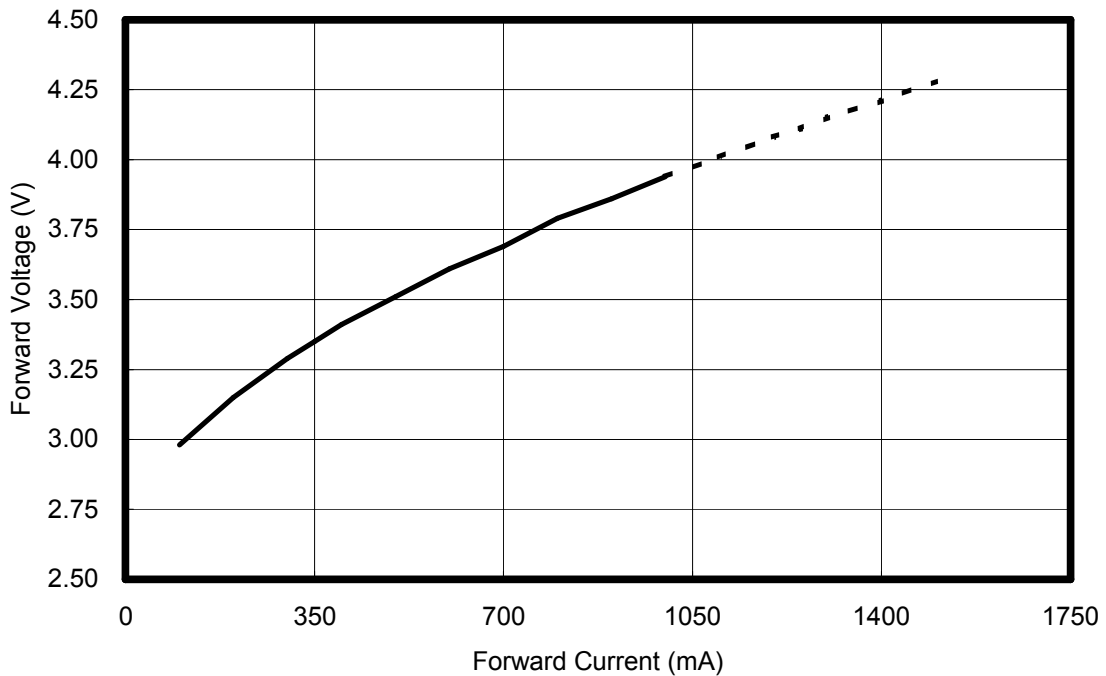

< Figure 13 Forward current & forward voltage for KLC8 and KLD8 at  $T_j=25^\circ\text{C}$  >

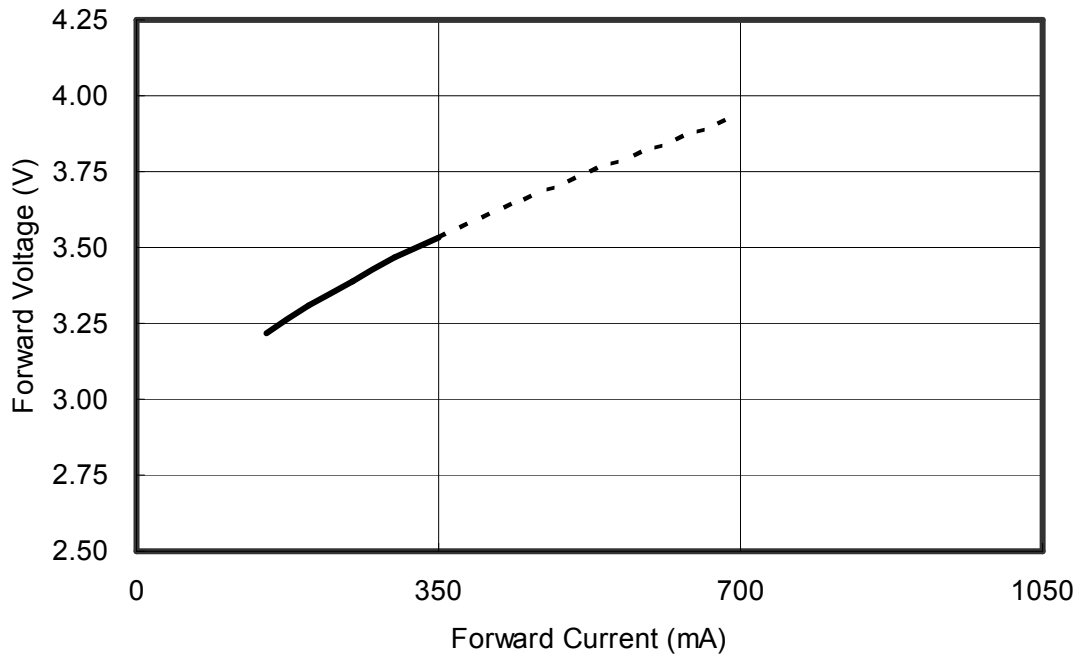

<Figure 14 Forward current & forward voltage for KLC9 at  $T_j=25^{\circ}\text{C}$ >

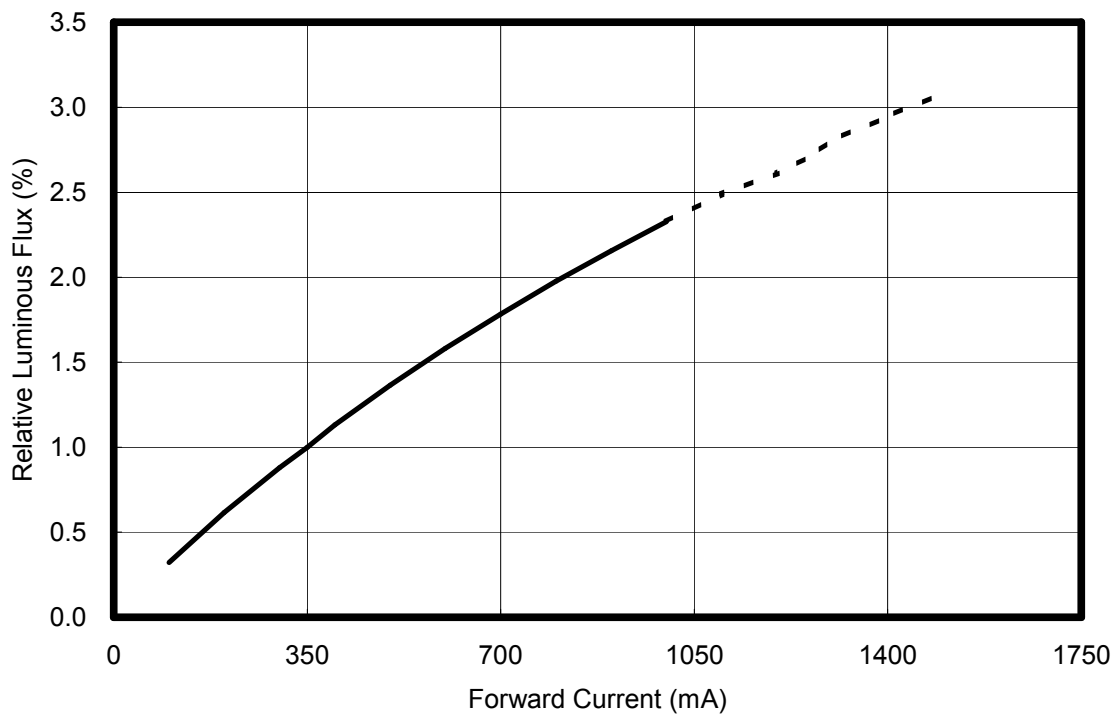

<Figure 15 Forward current & relative luminous for KLC8 and KLD8 at  $T_j=25^{\circ}\text{C}$ >

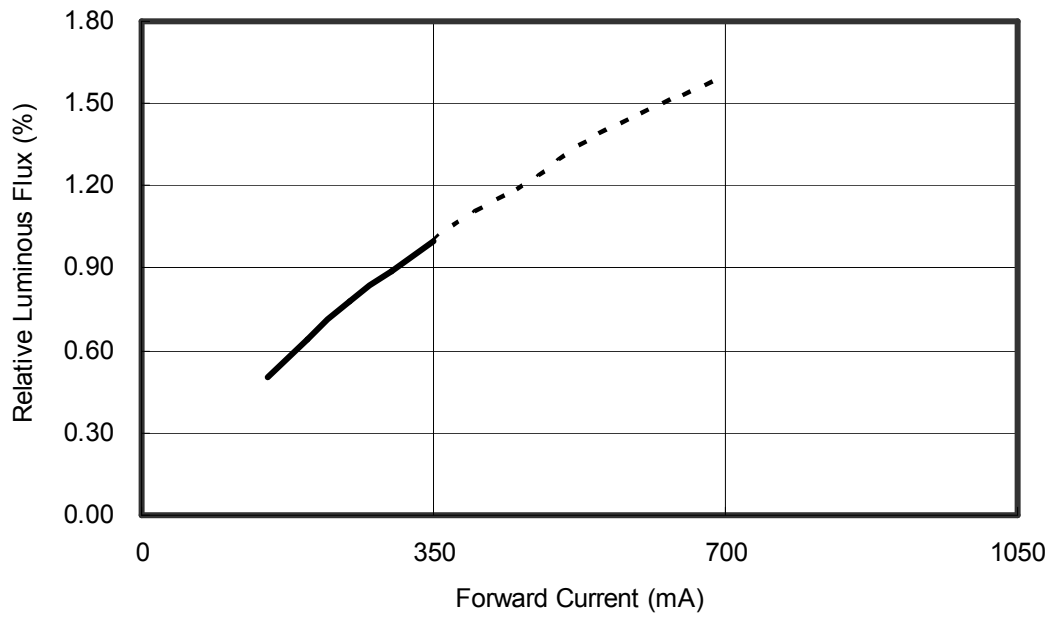

<Figure 16 Forward current & relative luminous for KLC9 at  $T_j=25^{\circ}\text{C}$ >

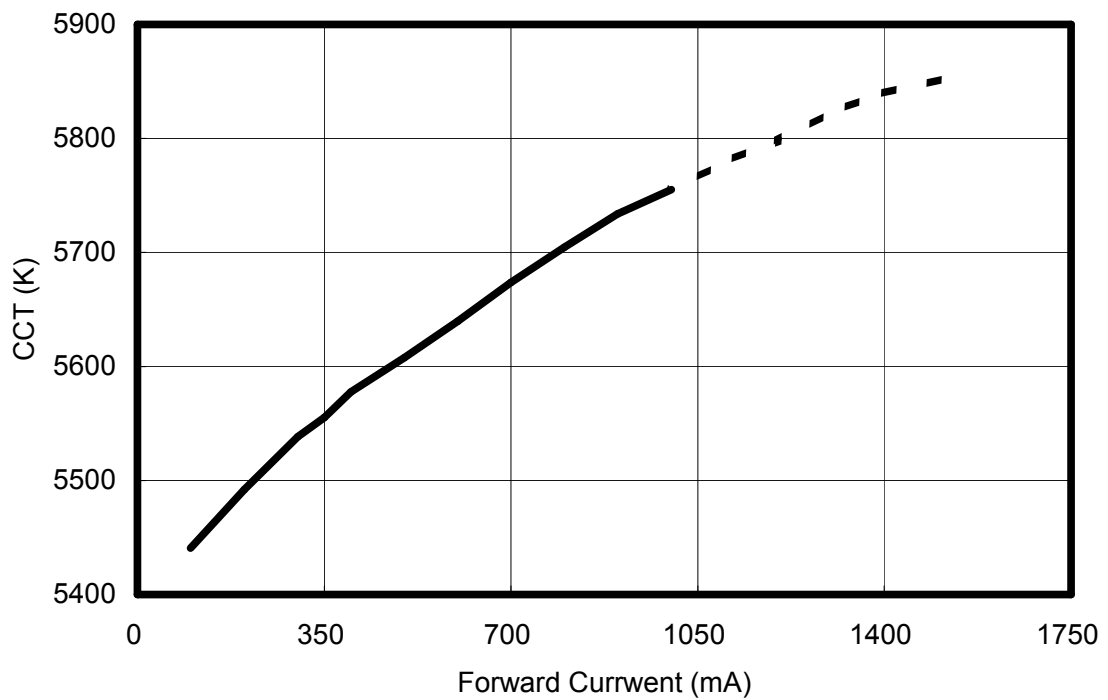

<Figure 17 Forward current & CCT for cool white at  $T_j=25^{\circ}\text{C}$ >

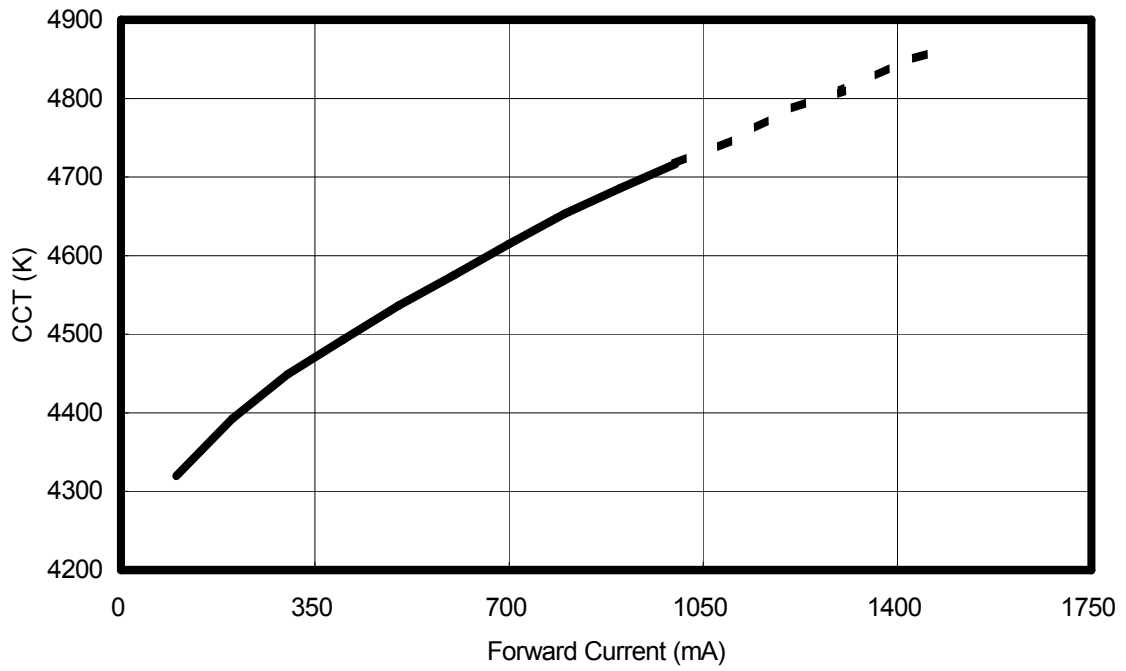

<Figure 18 Forward current & CCT for neutral white at  $T_J=25^{\circ}\text{C}$ >

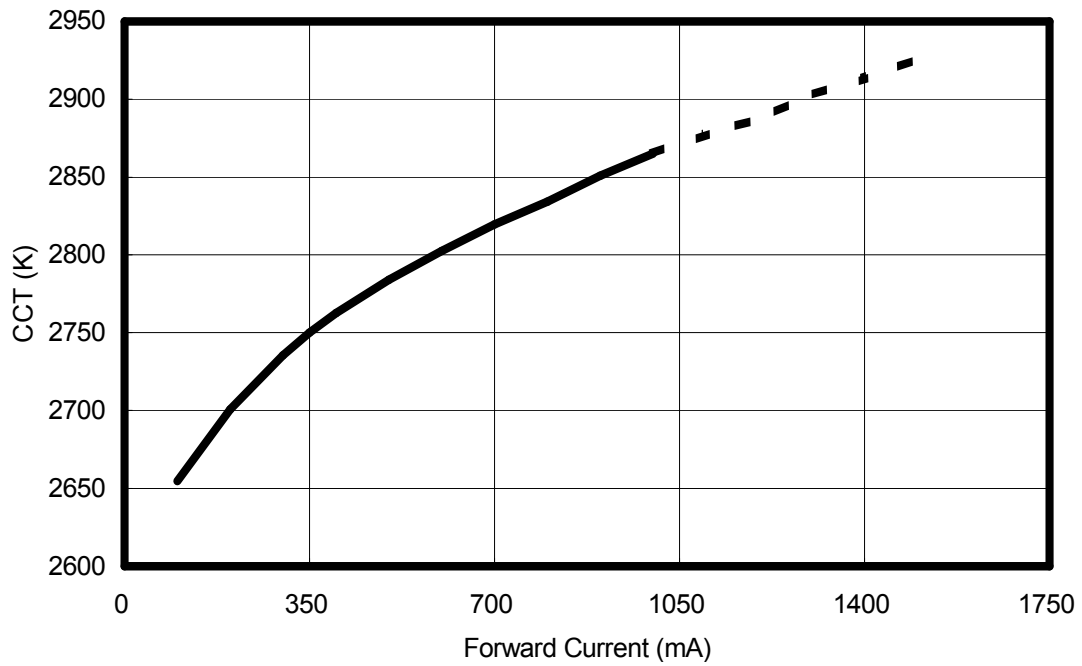

<Figure 19 Forward current & CCT for warm white at  $T_J=25^{\circ}\text{C}$ >

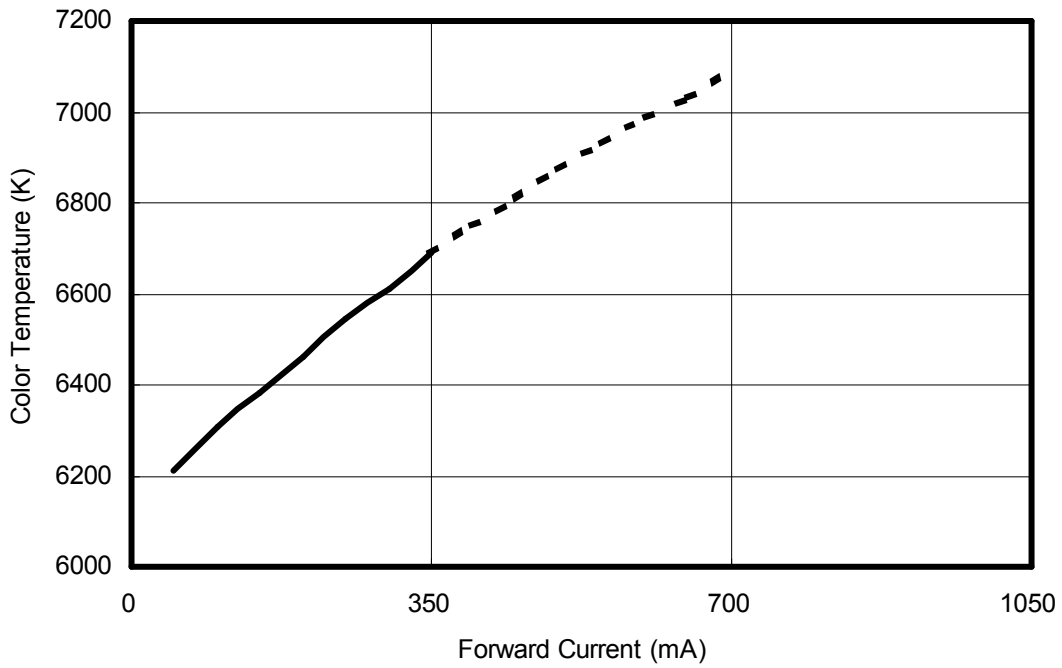

<Figure 20 Forward current & CCT for EDEW-KLC9 cool white at  $T_j=25^{\circ}\text{C}$ >

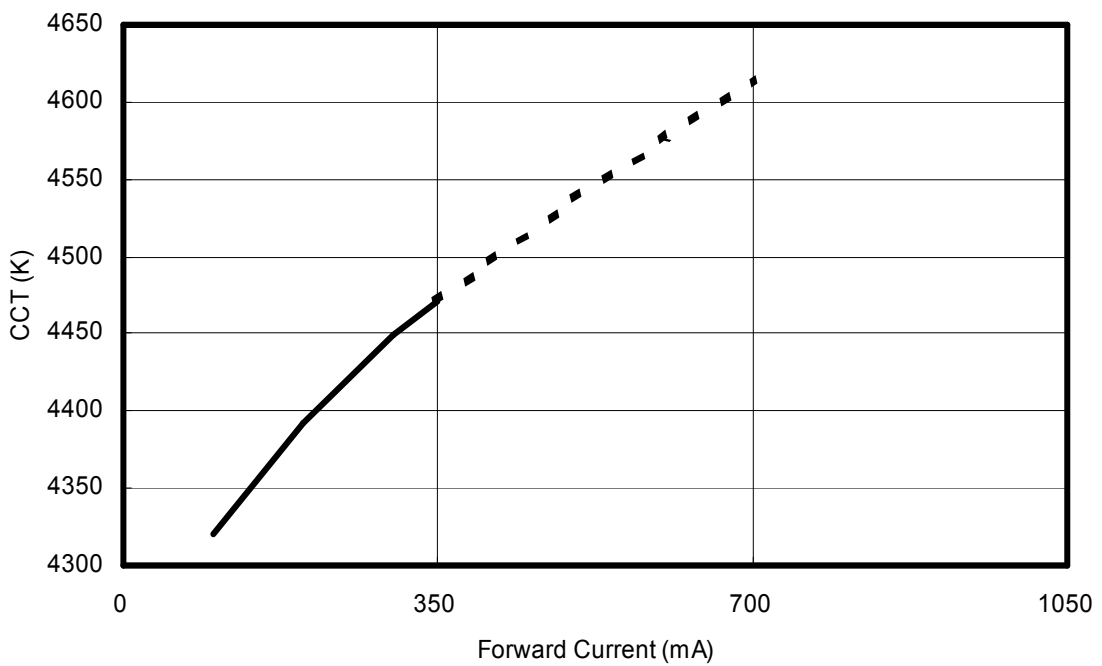

<Figure 21 Forward current & CCT for KLC9 neutral white at  $T_j=25^{\circ}\text{C}$ >

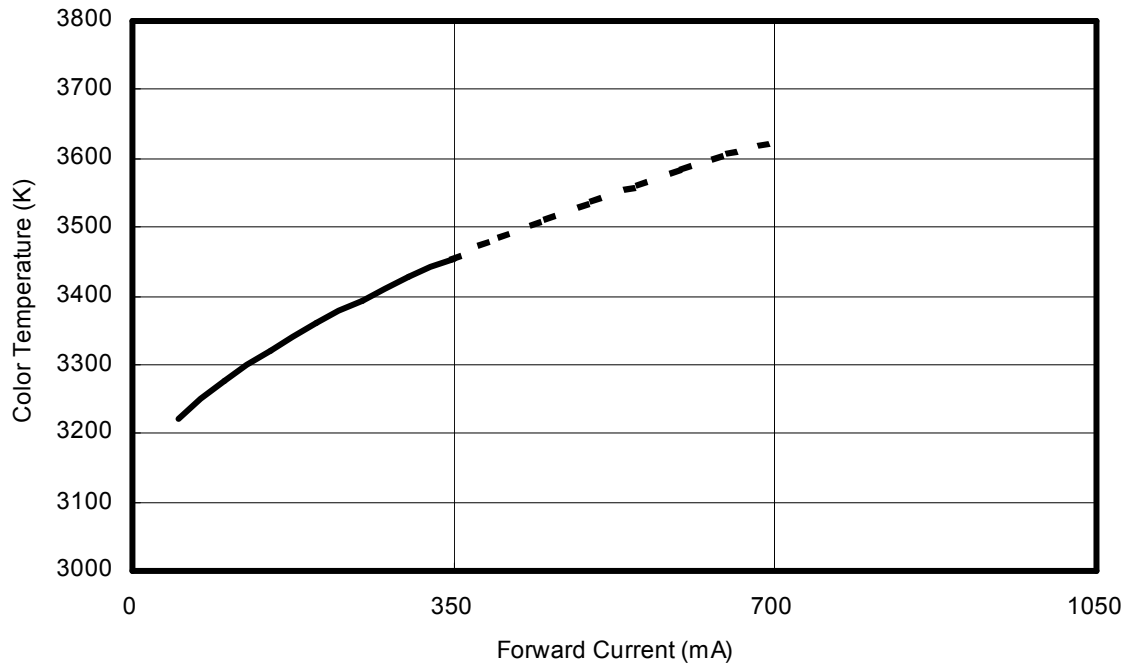

<Figure 22 Forward current & CCT for KLC9 warm white at  $T_j=25^{\circ}\text{C}$ >

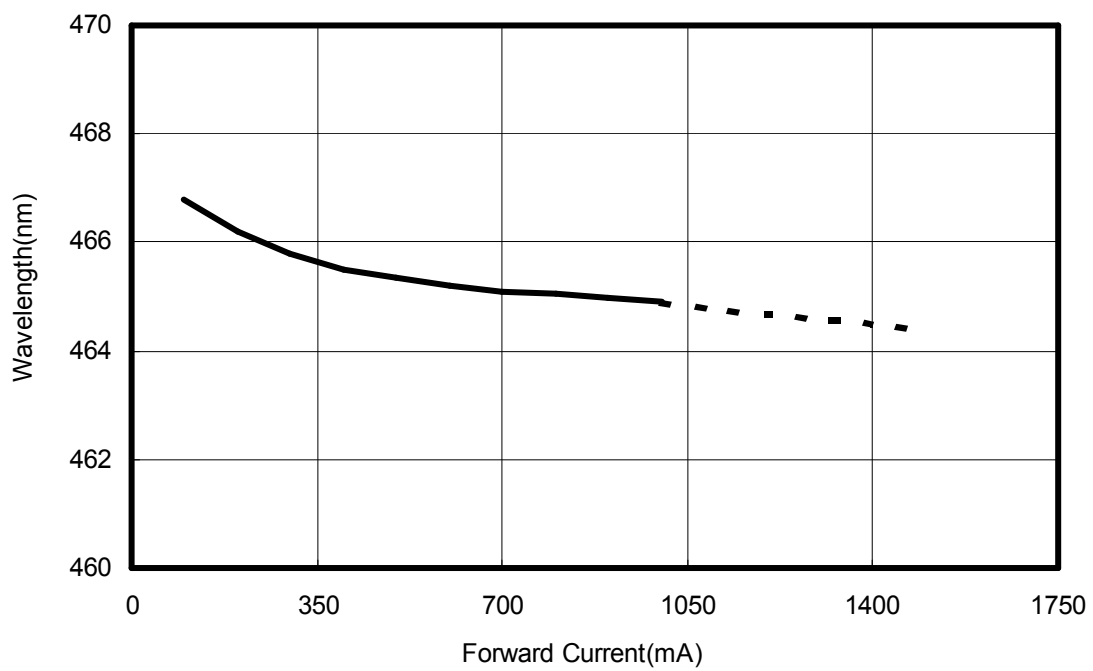

<Figure 23 Forward current & wavelength for KLC8 blue, royal blue at  $T_j=25^{\circ}\text{C}$ >

## Product Soldering Instructions

The central circle pad at the bottom face of the package provides the main path for heat dissipation from the LED to the heat sink (heat sink contact).

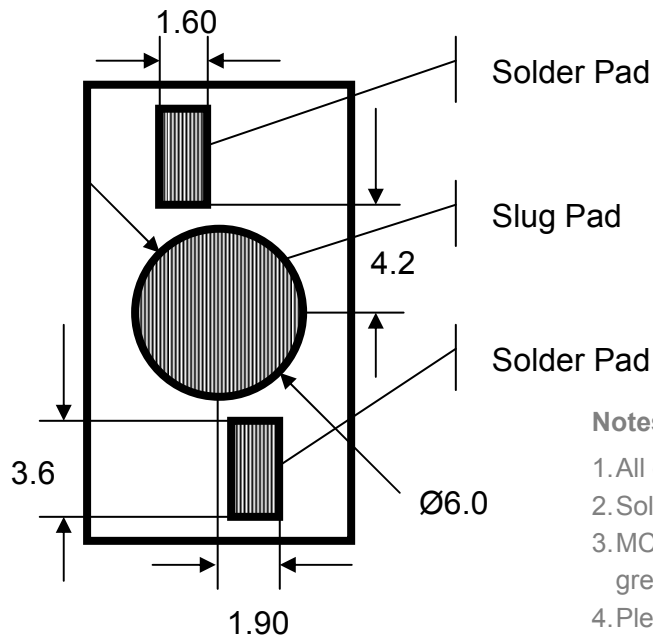

< Figure 24 Pad dimensions >

### Notes:

1. All dimensions are measured in mm.
2. Solder pad cannot be connected to slug pad.
3. MCPCB material with a thermal conductivity greater than 3.0 W/mK.
4. Please avoid touching the Edixeon® lens during assembly processes. This may cause pollution or scratch on the surface of lens.

The choice of solder and the application method will dictate the specific amount of solder. For most consistent results, an automated dispensing system or a solder stencil printer is recommended.

Positive results will be used solder thickness that results in 50µm. The lamp can be placed on the PCB simultaneously with any other required SMD devices and reflow completed in a single step. Automated pick-and-place tools are recommended.

The central slug at the bottom face of the package provides the main path for heat dissipation from the LED to the heat sink (heat sink contact). A key feature of Edixeon® emitter is an electrically neutral heat path that is separate from the LED's electrical contacts. This electrically isolated thermal pad makes Edixeon® emitter perfect for use with metal-core printed circuit boards (MCPCB).

---

### Recommend Solder Steps

To prevent mechanical failure of LEDs in the soldering process, a carefully controlled preheat and post-cooling sequence is necessary. The heating rate in an IR furnace depends on the absorption coefficients of the material surfaces and on the ratio of the component's mass to its irradiated surface. The temperature of parts in an IR furnace, with a mixture of radiation and convection, cannot be determined in advance.

Temperature measurement may be performed by measuring the temperature of a specific component while it is being transported through the furnace. Influencing parameters on the internal temperature of the component are as follows:

- Time and power
- Mass of the component (for Edixeon<sup>®</sup> K series on MCPCB)
- Absorption coefficient of the surfaces and MCPCB
- Packing density

Peak temperatures can vary greatly across the PC board during IR processes. The variables that contribute to this wide temperature range include the furnace type and the size, mass and relative location of the components on the board. Profiles must be carefully tested to determine the hottest and coolest points on the board. The hottest and coolest points should fall within the recommended temperatures. The profile of the reflow system should be based on design needs, the selected solder system and the solder-paste manufacturer's recommended reflow profile.

### Recommended Profile for Reflow Soldering

The following reflow soldering profiles are provided for reference. It is recommended that users follow the recommended soldering profile provided by the manufacturer of the solder paste used.

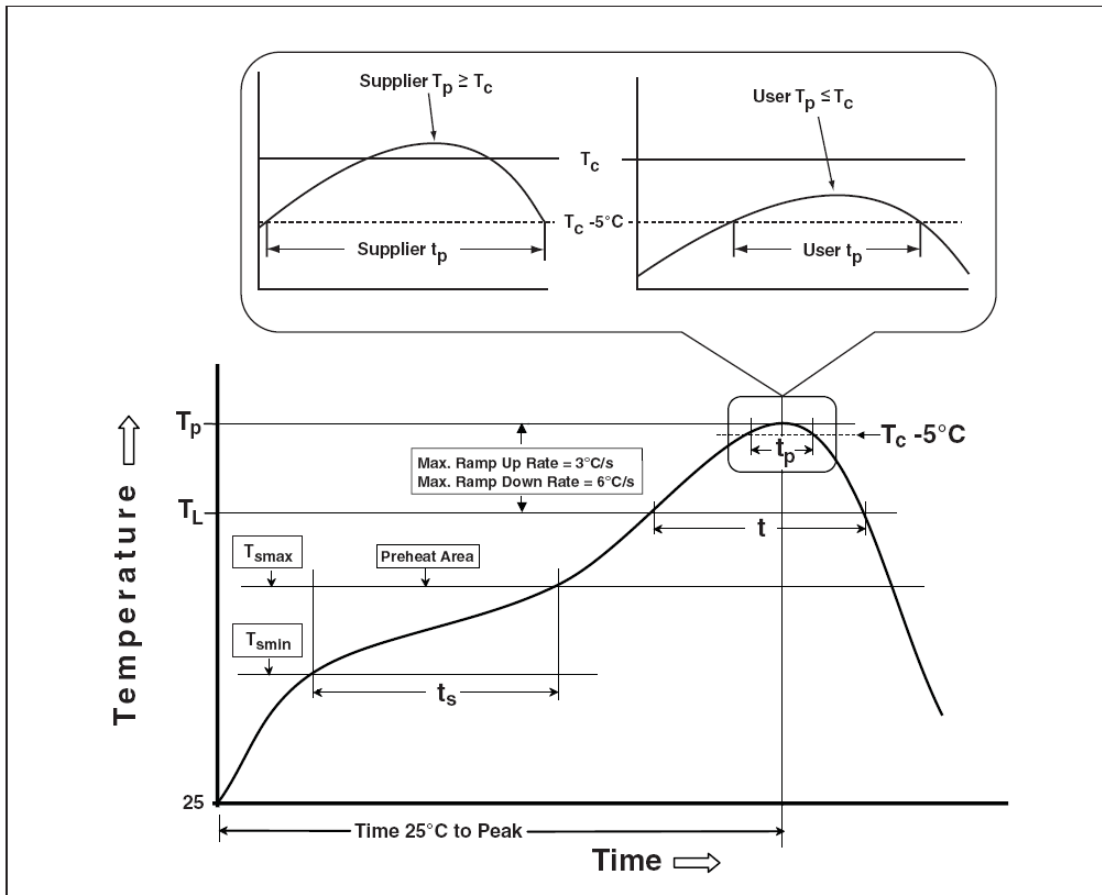

< Figure 25 Reflow profiles >

## Table of Classification Reflow Profiles

< Table 14 Reflow profiles >

Profile Feature	Sn-Pb Eutectic Assembly	Pb-Free Assembly
<b>Preheat &amp; Soak</b> Temperature min (T <sub>min</sub> ) Temperature max (T <sub>max</sub> ) Time (T <sub>min</sub> to T <sub>max</sub> ) (ts)	100 °C 150 °C 60-120 seconds	150 °C 200 °C 60-120 seconds
Average ramp-up rate (T <sub>max</sub> to T <sub>p</sub> )	3 °C/second max.	3 °C/second max.
Liquidous temperature (TL) Time at liquidous (tL)	183 °C 60-150 seconds	217 °C 60-150 seconds
Peak package body temperature (T <sub>p</sub> )*	230 °C ~235 °C *	255 °C ~260 °C *
Classification temperature (T <sub>c</sub> )	235 °C	260 °C
Time (t <sub>p</sub> )** within 5 °C of the specified classification temperature (T <sub>c</sub> )	20** seconds	30** seconds
Average ramp-down rate (T <sub>p</sub> to T <sub>max</sub> )	6 °C/second max.	6 °C/second max.
Time 25 °C to peak temperature	6 minutes max.	8 minutes max.

\* Tolerance for peak profile temperature (T<sub>p</sub>) is defined as a supplier minimum and a user maximum.

\*\* Tolerance for time at peak profile temperature (t<sub>p</sub>) is defined as a supplier minimum and a user maximum.

### Product Thermal Application Information

Thermal grease should be evenly spreaded with a thickness <math><100\mu\text{m}</math>.

When assembling on MCPCB or heat sink carrier.

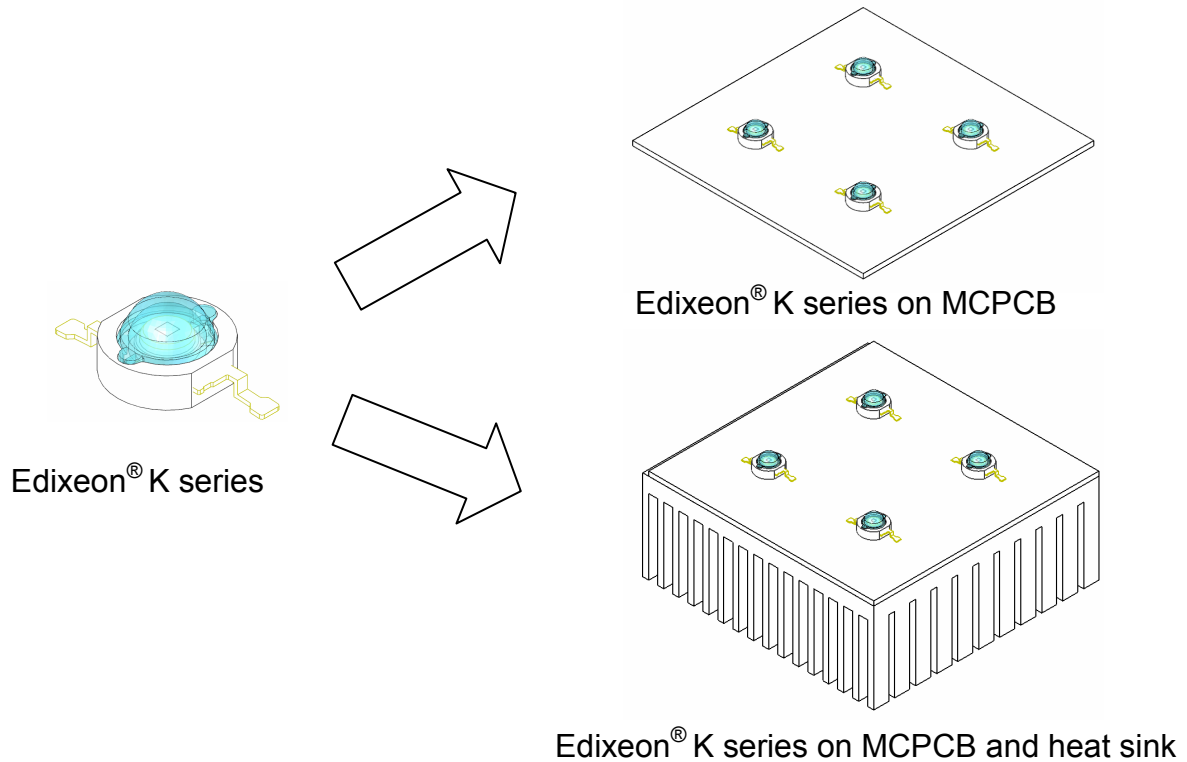

<Figure 26 Edixeon® K series heat sink application >

—It is strongly recommended the heat sink should be anodized.

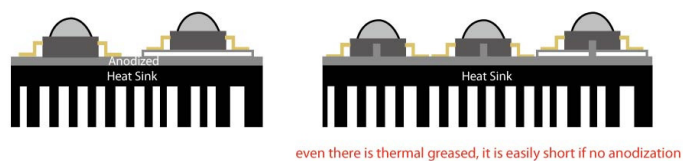

—Please ensure the heat sink is flat enough to prevent the bad heat conductivity.



<Figure 27 Edixeon® K series assemble with heat sink>

## Thermal Resistance Application

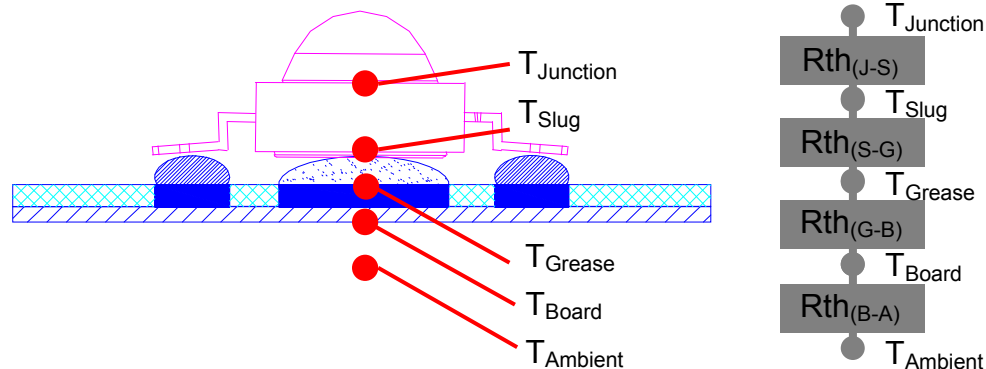

$$R_{th(J-A)} = R_{th(J-S)} + R_{th(S-G)} + R_{th(G-B)} + R_{th(B-A)}$$

$$T_{Junction} = T_{Ambient} + R_{th(J-A)} \times P_{Dissipation}$$

$$(T_J = T_A + R_{th(J-A)} \times P_{Dissipation})$$

<Figure 28 Rth and T<sub>J</sub> for Edixeon® K series >

## Suggested Adhesive for Selection(such as thermal grease)

- Ease of use
  - Non-solvent, One-part
- Fast tack free
  - 3 minutes at 25°C
- No corrosion
  - Alcohol type of room temperature vulcanization (RTV)
- Low volatility
  - Low weight loss of silicone volatiles
- Adhesion
  - Excellent adhesion to most materials without use of a primer
- Dielectric properties
  - Cured rubber exhibits good dielectric properties
- Excellent thermal stability and cold resistance
  - Cured rubber provides wide service temperature range

<Table 15 Specifications for adhesive properties >

Specification	Suggested Properties
Take-free time	3~10 minutes
Specific gravity	< 3 g/cm <sup>2</sup>
Thermal conductivity	> 2.5 W/mK
Rth in using	< 1.8 °C/W
Volume resistance	> 1x10 <sup>14</sup>
Lap shear adhesion strength	> 200 N/ cm <sup>2</sup>
Tensile strength	> 4 Mpa

### Thermal Resistance Calculation

The thermal resistance between two points is defined as the ratio of the difference in temperature to the power dissipated. For calculations in the following units used are °C/W. In the case of LEDs, the resistance of two important thermal paths affects the junction temperature:

From the LED junction to the thermal contact at the bottom of the package, this thermal resistance is governed by the package design. It is referred to as the thermal resistance between junction and slug ( $R_{th (J-S)}$ )

From the thermal contact to ambient conditions, this thermal resistance is defined by the path between the slug ,board ,and ambient. It is referred to as the thermal resistance between slug and board ( $R_{th (S-B)}$ ) and between board and ambient ( $R_{th (B-A)}$ ).

The overall thermal resistance between the LED junction and ambient ( $R_{th (J-A)}$ ) can be modeled as the sum of the series resistances  $R_{th (J-S)}$  ,  $R_{th (S-B)}$  , and  $R_{th (B-A)}$ .

The following will show how to calculate  $R_{th}$  for each part of LED module.

#### 1. $R_{th (J-S)}$

Assume Edixeon®  $R_{th (J-S)}=8\text{ °C/W}$

#### 2. $R_{th (S-G)}$

If the thickness of thermal grease is 100um and area is  $(6.4/2)^2\pi\text{ mm}^2$ .

Thermal conductivity of thermal grease is 2.6 W/mK.

The Formula of  $R_{th}$  is 
$$\frac{\text{Thickness(um)}}{\text{Thermal Conductivity (W/mK) x Area(mm}^2\text{)}}$$

$$\text{Therefore } R_{th(S-G)} = \frac{100}{2.6 \times (6.4/2)^2 \pi} = 1.2 \text{ } ^\circ\text{C/W}$$

### 3. $R_{th(G-B)}$

The  $R_{th}$  of standard MCPCB is  $1.5 \text{ } ^\circ\text{C/W}$

### 4. $R_{th(B-A)}$

The  $R_{th}$  between board and air is mainly dependent on the total surface area.

$$\text{Therefore } R_{th(B-A)} \doteq \frac{500}{\text{Area}(\text{cm}^2)}$$

If Area is $30\text{cm}^2$ $R_{th}=16.7$	$R_{th(J-A)} = 8+1.2+1.5+16.7 = 27.4 \text{ } ^\circ\text{C/W}$
If Area is $60\text{cm}^2$ $R_{th}=8.3$	$R_{th(J-A)} = 8+1.2+1.5+8.3 = 19 \text{ } ^\circ\text{C/W}$
If Area is $90\text{cm}^2$ $R_{th}=5.5$	$R_{th(J-A)} = 8+1.2+1.5+5.5 = 16.2 \text{ } ^\circ\text{C/W}$

## Junction Temperature Calculation

The total power dissipated by the LED is the product of the forward voltage ( $V_F$ ) and the forward current ( $I_F$ ) of the LED.

The temperature of the LED junction is the sum of the ambient temperature and the product of the thermal resistance from junction to ambient and the power dissipated.

$$T_{\text{Junction}} = T_{\text{Air}} + R_{th(J-A)} \times P_{\text{Dissipation}}$$

If one white Edixeon<sup>®</sup> in room temperature ( $25^\circ\text{C}$ ) operated  $350\text{mA}$  and  $V_F=3.3\text{V}$ , the  $P_{\text{Dissipation}}=0.35 \times 3.3=1.155\text{W}$

And junction temperature is

$$T_{\text{Junction}} = 25^\circ\text{C} + 18.2 \times 1.155 = 46.021^\circ\text{C} \text{ (total surface area } = 90\text{cm}^2)$$

$$T_{\text{Junction}} = 25^\circ\text{C} + 21 \times 1.155 = 49.255^\circ\text{C} \text{ (total surface area } = 60\text{cm}^2)$$

$$T_{\text{Junction}} = 25^\circ\text{C} + 29.4 \times 1.155 = 58.957^\circ\text{C} \text{ (total surface area } = 30\text{cm}^2)$$

## Example : Junction Temperature Calculation

*One white LED is used under ambient temperature ( $T_{\text{Ambient}}$ ) of  $30^\circ\text{C}$ . This LED is soldered on MCPCB (Area= $10\text{cm}^2$ ). Calculate junction temperature.*

Assuming a forward voltage of  $V_F=3.3\text{V}$  at  $350\text{mA}$  and total power dissipated is

$$P_{\text{Dissipation}} = 1 \times 0.35 \times 3.3 = 1.155 \text{ W.}$$

$$\text{LED } R_{th(J-S)} = 8 \text{ } ^\circ\text{C/W.}$$

With good design,  $R_{th(S-G)}$  can be minimized to  $1 \text{ } ^\circ\text{C/W}$ .

$R_{th(G-B)}$  of a standard MCPCB can be  $1.5 \text{ } ^\circ\text{C/W}$ .

The Rth between board and air is mainly dependent on the total surface area.

Therefore it can be calculated in formula  $\frac{500}{\text{Area}(\text{cm})^2}$

$$R_{th(B-A)} = \frac{500}{10} = 50 \text{ } ^\circ\text{C/W}.$$

Following the formula  $T_{\text{Junction}} = T_{\text{Ambient}} + R_{th(J-A)} \times P_{\text{Dissipation}}$

$$T_{\text{Junction}} = 30 \text{ } ^\circ\text{C} + (8 \text{ } ^\circ\text{C/W} + 1 \text{ } ^\circ\text{C/W} + 1.5 \text{ } ^\circ\text{C/W} + 50 \text{ } ^\circ\text{C/W}) \times 1.155\text{W}$$
$$= 99.8775 \text{ } ^\circ\text{C}$$

That means this LED emitter is operated under good condition ( $T_{\text{Junction}} < 125 \text{ } ^\circ\text{C}$ ).

It's strongly recommended to keep the junction temperature under  $125 \text{ } ^\circ\text{C}$

Or keep the temperature of emitter lead not exceed  $55 \text{ } ^\circ\text{C}$

## Product Electrical Application Information

Following graphs and descriptions show how to connect LED or LED module and plug to AC outlet.

Step1: Connect the wires of LED Module to the DC output of the driver.

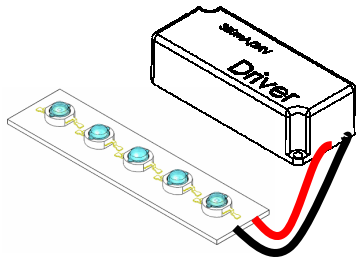

<Figure 29 LED Module connect to the DC output of the driver>

Step2 : Plug the driver to AC outlet.

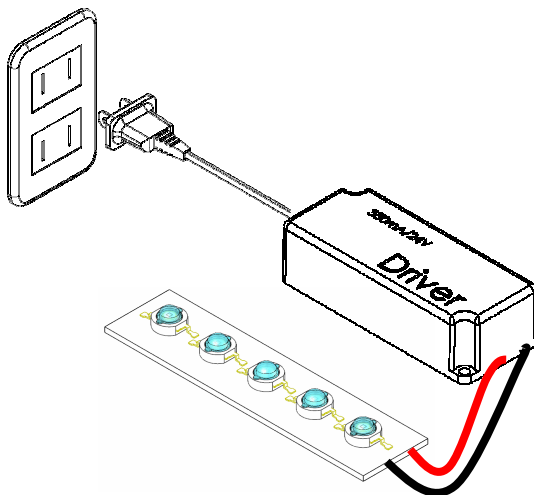

<Figure 30 Plug the AC output of the driver to AC outlet>

Caution: Never plug the driver to AC outlet before the LED Module is properly connected as this may generate transient voltage damage the LEDs permanently with a short or open circuit.

## Product Packaging Information

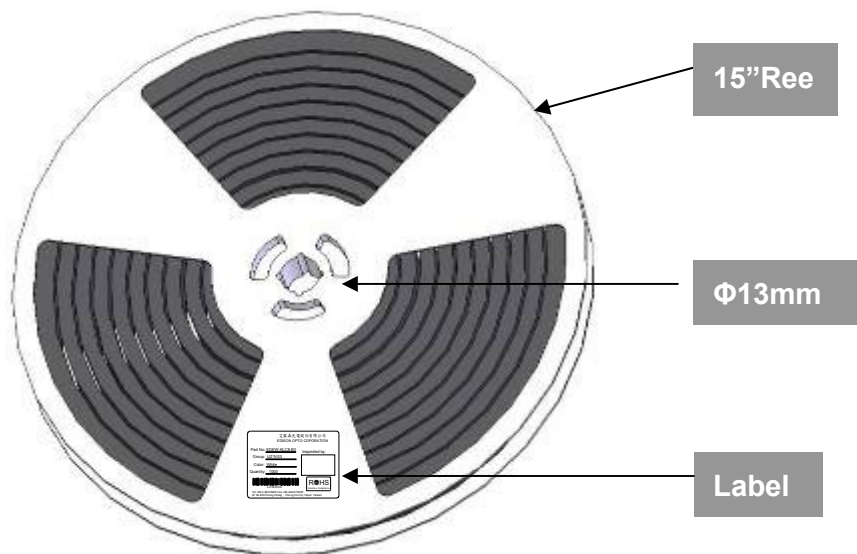
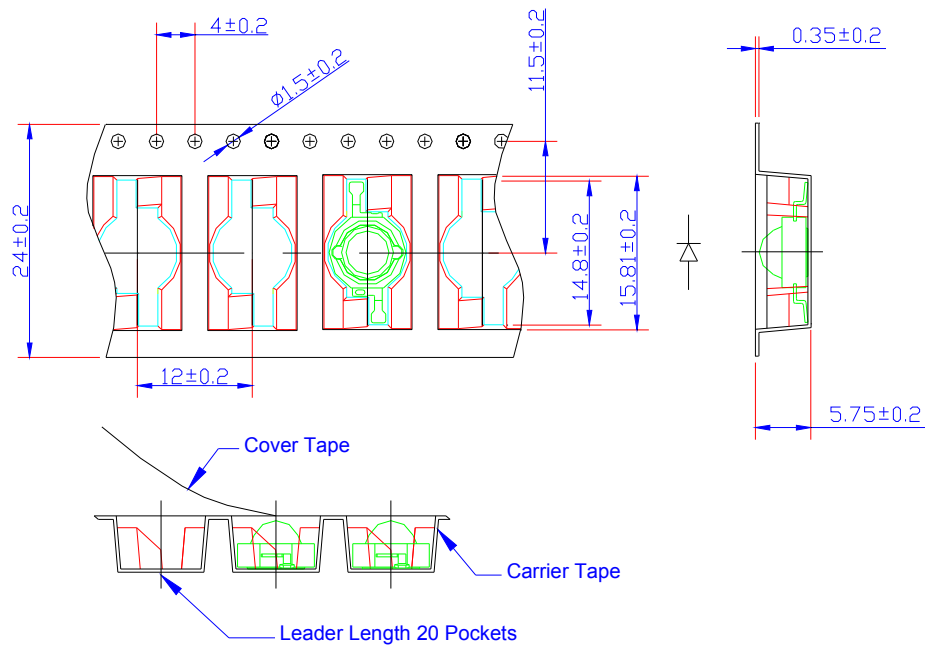

< Figure 31 Taping reel dimensions >

## The Label



< Figure 32 Label on taping reel >

## Packaging Steps

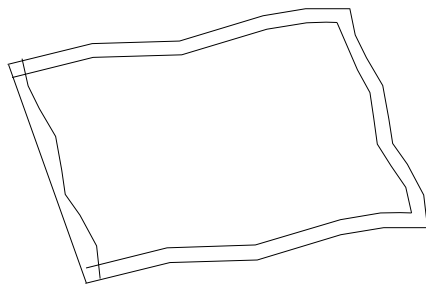

1 reel in a bag.

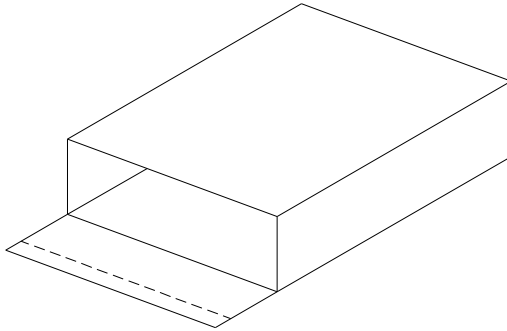

2 bags in an inner box.

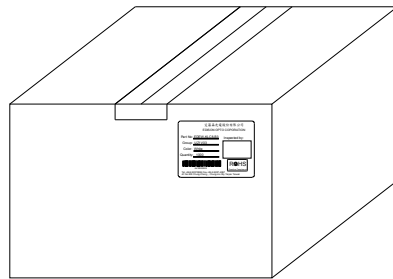

2 inner boxes in an outer box.

< Figure 33 Packaging steps >

### Notes:

1. All dimensions are in mm.
2. There are 1000pcs emitters in a full reel.
3. There is one reel in a bag.
4. There are 2 bags in an inner box.
5. There are 2 inner boxes in an outer box.
6. A bag contains one humidity indicator card and drying agent.

## Star Product Packaging Information

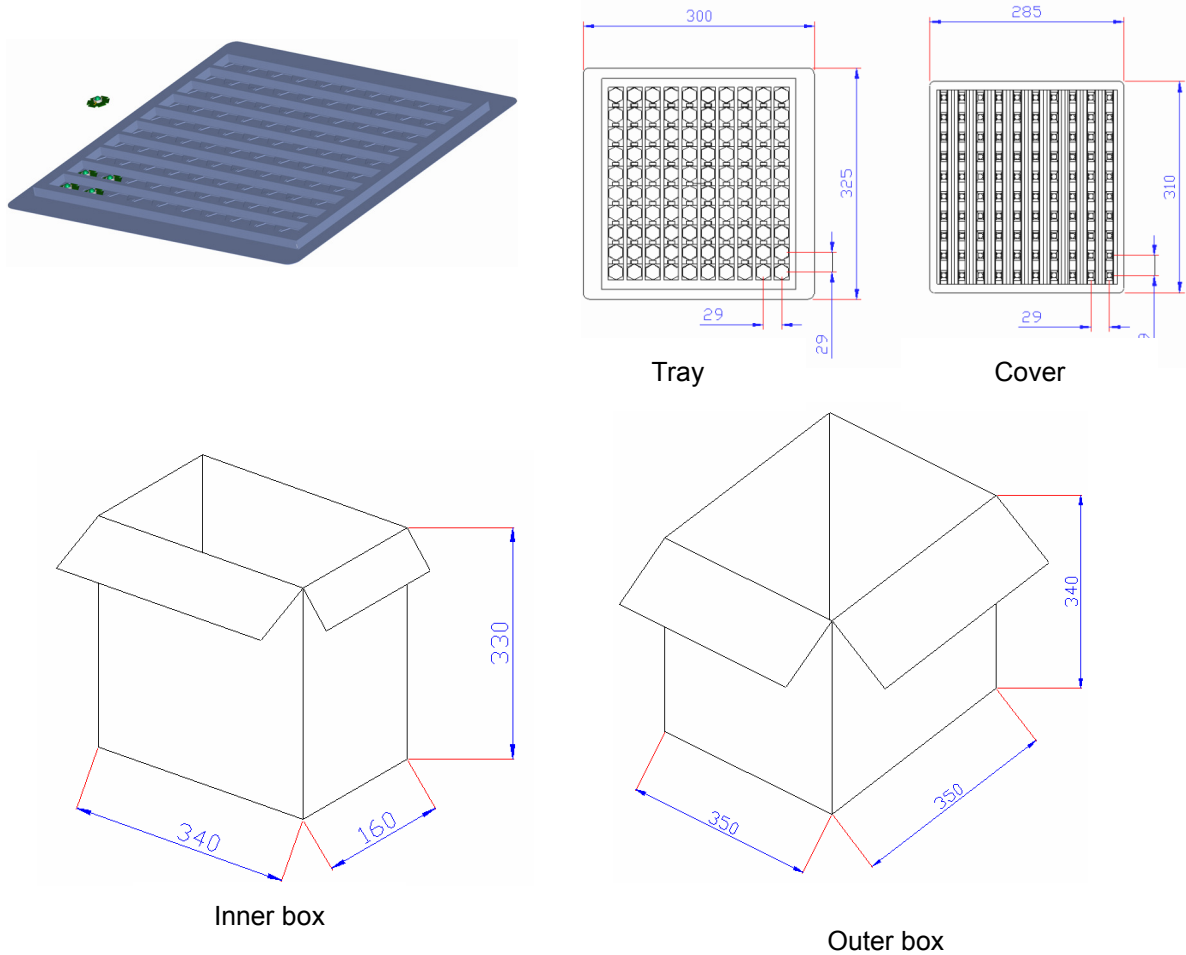

<Figure 33 Edixon® star package and dimensions >

### Notes:

1. All Dimensions are in mm.
2. There are 100 pcs stars in a tray.(Tray+Cover)
3. There are 10 trays in an inner box.
4. There are 2 inner boxes in an outer box.

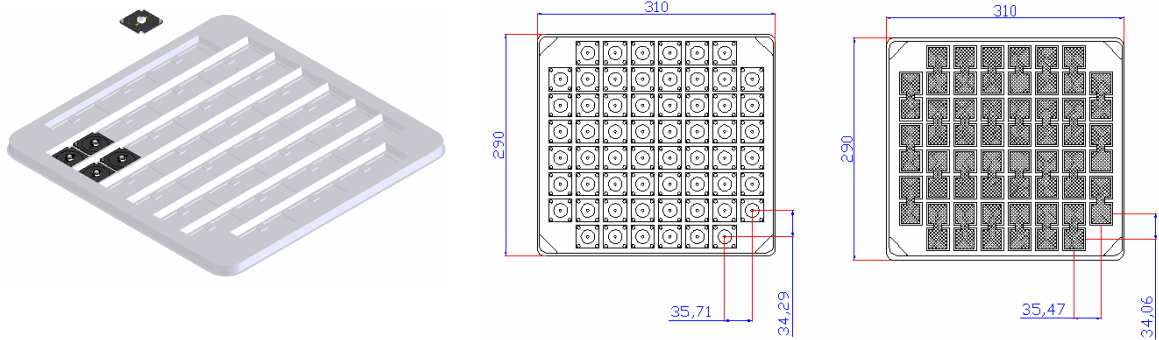

Tray

Cover

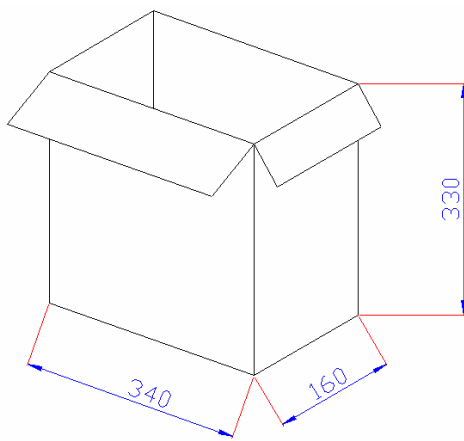

Inner box

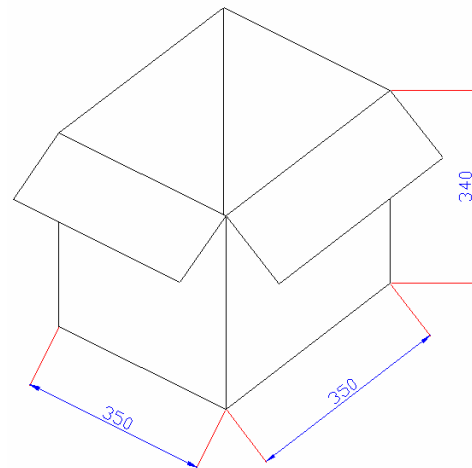

Outer box

<Figure 34 Edixeon® star package and dimensions >

**Notes:**

1. All Dimensions are in mm.
2. There are 60 pcs stars in a tray.(Tray+Cover)
3. There are 10 trays in an inner box.
4. There are 2 inner boxes in an outer box.